

NOTE:
FINAL PAVEMENT RESTORATION FOR TYPE "B" TRENCHES SHALL BE AGAINST A SAW CUT LINE.

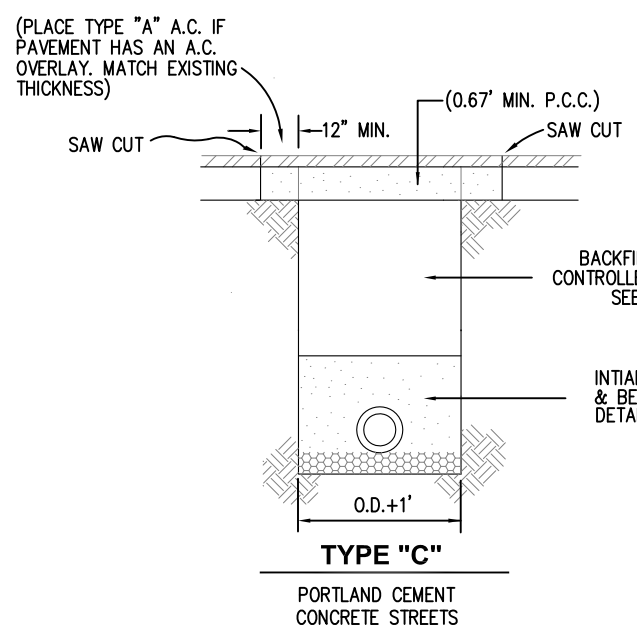

- NOTES:**
1. TYPE "A" & "C" TRENCHES REQUIRE (2) TWO CUTS; FIRST CUT INITIAL TRENCH WIDTH THEN AFTER WORK HAS BEEN COMPLETED, IT SHALL BE SAW CUT A MINIMUM OF 12" WIDER BOTH SIDES.
 2. THERE SHALL BE A 7 DAY WAITING PERIOD PRIOR TO SUBJECTING THE TRENCH BACKFILL TO TRAFFIC LOADS. THIS TIME PERIOD CAN BE REDUCED IF, IN THE OPINION OF THE ENGINEER, THE C.D.F. IS ADEQUATELY FIRM AND STABLE.
 3. STRUCTURAL THICKNESSES SHOWN ARE MINIMUM ALLOWABLE. INCREASED THICKNESS OF STRUCTURAL SECTIONS MAY BE REQUIRED BY CITY ENGINEER IF EXISTING STRUCTURAL SECTION EXCEEDS THESE MINIMUMS.
 4. ALL TRENCH WORK 5' AND DEEPER SHALL HAVE APPROVED SHORING, ALL IN ACCORDANCE WITH CITY SPECIAL PROVISION "TRENCHING OPERATIONS".
 5. PAVING SURFACE AT TRENCH JOINTS SHALL BE SEALED WITH ASPHALT EMULSION 4" EACH SIDE OF JOINT AFTER FINAL COMPACTION OF ASPHALT CONCRETE. SEALANT SHALL BE SANDED AS NECESSARY TO PREVENT TRAFFIC PICKUP.
 6. IF FINAL PAVEMENT RESTORATION WILL NOT BE INSTALLED BY THE END OF THE WORK DAY THAT TRENCH PLATES ARE REMOVED, PLACE 1" INCH MINIMUM TEMPORARY PAVEMENT (SC-800 COLD MIX) AND COMPACT IN PLACE USING A VIBRATING ROLLER OR VIBROPLATE.
 7. THICKNESS TO BE 0.25' MIN OR MATCH EXISTING; WHICHEVER IS GREATER.
 8. SEE CITY SPECIAL PROVISIONS FOR CONTROLLED DENSITY MIX DESIGN.
 9. PLACEMENT OF ASPHALT CONCRETE SHALL BE IN ACCORDANCE WITH SECTION 39 OF THE CALTRANS STANDARDS SPECIFICATIONS, UNLESS OTHERWISE APPROVED BY THE CITY ENGINEER.

CDF - FINAL BACKFILL & TRENCH RESTORATION

DATE	REVISIONS	BY

CITY OF YUBA CITY	
STANDARD DETAIL	
TR2	
APPROVED _____	DATE _____