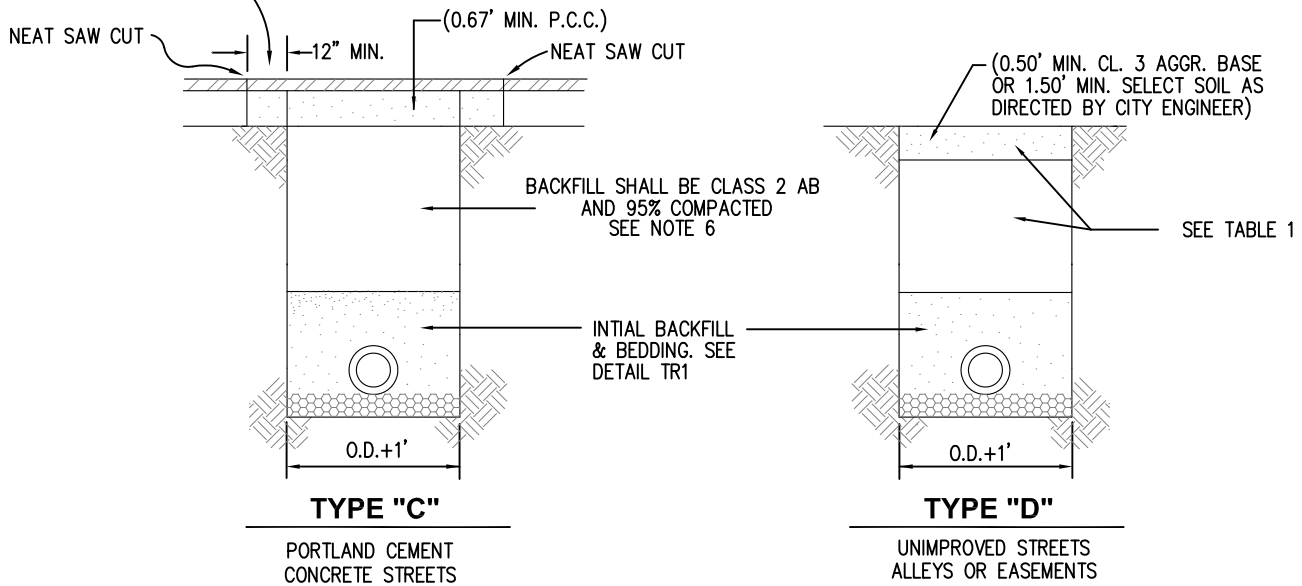

TABLE 1

TYPE	LOCATION	BACKFILL & COMP.	RESTORATION TYPE
D-1	WITHIN 3' E.P.	CLASS 2 AB 95%	6" CL. 3 A.B.
D-2	GREATER THAN 3' TO E.P.	SELECT SOIL 90%	1.5' MIN. SELECT SOIL
D-(SW)	SIDEWALK AREAS	CLASS 2 AB 95%	6" P.C.C. OR EQUAL TO EXIST. WHICHEVER IS GREATER

(PLACE TYPE "A" A.C. IF PAVEMENT HAS AN A.C. OVERLAY) SEE NOTE 5



NOTES:

- TYPE "A" & "C" TRENCHES REQUIRE (2) TWO CUTS; FIRST CUT INITIAL TRENCH WIDTH. THEN 30 DAYS AFTER WORK HAS BEEN COMPLETED IT SHALL BE SAW CUT A MINIMUM OF 12" WIDER BOTH SIDES.
- TYPE "A" & "C" TRENCHES REQUIRE PLACEMENT AND MAINTENANCE OF TEMPORARY PAVEMENT (SC-800 COLD MIX), COMPACTED IN PLACE USING A VIBRATING ROLLER OR VIBROPLATE, FOR A MINIMUM OF 30 DAYS PRIOR TO PERMANENT PAVING.
- STRUCTURAL THICKNESSES SHOWN ARE MINIMUM ALLOWABLE. INCREASED THICKNESS OF STRUCTURAL SECTIONS MAY BE REQUIRED BY CITY ENGINEER IF EXISTING STRUCTURAL SECTION EXCEEDS THESE MINIMUMS.
- ALL TRENCH WORK 5' AND DEEPER SHALL HAVE APPROVED SHORING, ALL IN ACCORDANCE WITH CITY SPECIAL PROVISION "TRENCHING OPERATIONS".
- PAVING SURFACE AT TRENCH JOINTS SHALL BE SEALED WITH ASPHALT EMULSION 4" EACH SIDE OF JOINT AFTER FINAL COMPACTION OF ASPHALT CONCRETE. SEALANT SHALL BE SANDED AS NECESSARY TO PREVENT TRAFFIC PICKUP.
- THE COMPACTION OF THE MATERIAL SHALL BE IN ACCORDANCE WITH CITY SPECIAL PROVISIONS "QUANTITIES AND MATERIALS".
- THICKNESS IS TO BE 0.25' MIN OR MATCH EXISTING; WHICHEVER IS GREATER.
- PLACEMENT OF ASPHALT CONCRETE SHALL BE IN ACCORDANCE WITH SECTION 39 OF THE CALTRANS STANDARD SPECIFICATIONS, UNLESS OTHERWISE APPROVED BY THE CITY ENGINEER.

CLASS 2 AB - FINAL BACKFILL & TRENCH RESTORATION

DATE	REVISIONS	BY

CITY OF YUBA CITY	
STANDARD DETAIL	
TR3	
APPROVED	DATE