

CITY OF YUBA CITY
STAFF REPORT

Date: May 17, 2022
To: Honorable Mayor & Members of the City Council
From: Finance/IT Department
Presentation By: Spencer Morrison, Finance Director

Summary

Subject: Two (2) Dump Truck Chassis and (1) Aerial Tree Truck Award

Recommendation: A. Adopt a Resolution awarding the purchase of two (2) 10-yard dump trucks to PB Loader, of Fresno, CA, in the amount of \$360,933.92 plus a 10% contingency of \$33,119.08, and one (1) aerial tree truck to Terex Utilities, Inc., of Watertown, SD, in the amount of \$250,504.90 plus a 10% contingency of \$23,357.10, all using Sourcewell contract pricing quotes and utilizing Section 9.8 of the Purchasing Policy finding it is in the best interest of the City

B. Appropriate \$517,463.80 for the above purchases in the Vehicle Replacement Fund

Fiscal Impact: \$517,463.80 Vehicle Replacement Fund Account 6610-69410

Purpose:

Purchase of replacement trucks for the Water Distribution, Sewer Collection, and Parks Maintenance divisions.

Council's Strategic Goal:

This staff report addresses the City Council's Strategic Goal of fiscal responsibility.

Background:

The California Clean Air Regulations are state air quality laws that have created an end-of-life situation for several City vehicles with diesel powerplants. Staff has struggled finding available chassis in recent years due to various supply chain issues and has located a dump truck chassis that satisfies the 10-yard dump truck purchase authorization granted by City Council on August 17, 2021, and chassis for two additional vehicle replacements slated for the current fiscal year: another 10-yard dump truck for the Water Distribution division and an Aerial Tree Truck for the Parks Maintenance division. The Resolution adopted on August 17th authorized the lease financing of one 10-yard dump truck in the amount of \$150,451.20, among other vehicles.

Analysis:

Once funding for a 10-yard dump truck was secured at the August 17th council meeting, staff worked with the approved vendor, PB Loader to find a chassis. In late April, Public Works staff received notice that two chassis are available and this request is an attempt to purchase both chassis: one approved and a second in anticipation of a second dump truck becoming out of compliance. The price of these chassis has increased by nearly \$30,000 from the amount City Council approved, \$150,451.20, and requires additional appropriation. Public Works staff has secured Sourcewell cooperative contract pricing and will use Section 9.8 of the City's Purchasing Policy to accept the quote.

An aerial tree truck was approved in the FY 2020-21 capital acquisitions budget. After much discussion about budget, leasing versus buying, and supply-chain related price increases, staff recommends purchasing this aerial truck using funds saved in the Vehicle Replacement Fund for this vehicle, \$253,000.

Fiscal Impact:

A total of \$517,463.80 will be purchased using the Vehicle Replacement Fund account, 6610-69410.

Recommendation:

A. Adopt a Resolution awarding the purchase of two (2) 10-yard dump trucks to PB Loader, of Fresno, CA, in the amount of \$360,933.92 plus a 10% contingency of \$33,119.08, and one (1) aerial tree truck to Terex Utilities, Inc., of Watertown, SD, in the amount of \$250,504.90 plus a 10% contingency of \$23,357.10, all using Sourcewell contract pricing quotes and utilizing Section 9.8 of the Purchasing Policy finding it is in the best interest of the City.

B. Appropriate \$517,463.80 for the above purchases in the Vehicle Replacement Fund.

Alternatives:

1. Reject all Sourcewell pricing
2. Request a formal bid process
3. Do not authorize purchases

Attachments:

1. Resolution
2. Quote - 10-Yard Dump Truck
3. Quote - Aerial Tree Truck

Prepared By:
Spencer Morrison
Finance Director

Submitted By:
Diana Langley
City Manager

ATTACHMENT 1

RESOLUTION NO. ____

**RESOLUTION OF THE CITY COUNCIL OF THE CITY OF YUBA CITY
AWARDING THE PURCHASE OF TWO (2) 10-YARD DUMP TRUCKS AND
ONE (1) AERIAL TREE TRUCK**

WHEREAS, the California Clean Air Regulations require certain diesel-powered vehicles in Yuba City's fleet to be replaced by January, 2023; and

WHEREAS, the City's Fleet Maintenance staff has identified vehicles to be replaced per the regulations or due to vehicles' ages and maintenance records, including two (2) 10-yard dump trucks and an aerial tree truck; and

WHEREAS, the City has been unsuccessful in obtaining one of the above-mentioned 10-yard dump trucks authorized by City Council at the August 17, 2021, meeting and pricing for that vehicle have increased by \$30,000 due to increased manufacturing costs, and;

WHEREAS, City staff has found heavy-duty chassis suitable for assembling the three trucks and has elected to utilize Section 9.8, the piggyback clause, in the City's Purchasing Policy to streamline the purchasing process in order to control costs and finding that it is in the best interest of the city; and

WHEREAS, the City has elected to use Sourcewell, a government cooperative purchasing source that provides access competitively sourced contracts; and

WHEREAS, heavy duty trucks are difficult to obtain in 2022 and decision delays are fraught with steel surcharges, supply chain woes, and other factors that are increasing prices every three to six months; and

WHEREAS, City staff recommends awarding the purchase of two (2) 10-yard dump trucks to PB Loader Corporation of Fresno, CA, a Sourcewell pricing supplier; and

WHEREAS, City staff recommends awarding the purchase of one (1) aerial tree truck to Terex Utilities of Watertown, SD, a Sourcewell pricing supplier; and

NOW, THEREFORE, the City Council of the City of Yuba City does resolve as follows:

1. The City Council of Yuba City finds that Sourcewell provided contracts at a fair and reasonable cost. The City Council hereby authorizes the City Manager to purchase the two 10-yard dump trucks and one aerial tree truck, allowing for a 10% contingency for unforeseen price increases or surcharges, utilizing \$517,463.80 from the Vehicle Replacement Fund, 6610-69410, without additional written consent from the City, subject to approval as to legal form by the City Attorney.
2. This Resolution shall take effect immediately.

The foregoing Resolution was duly and regularly introduced, passed, and adopted by the City Council of the City of Yuba City at a regular meeting thereof held on the 17th day of May, 2022.

AYES:

NOES:

ABSENT:

Dave Shaw, Mayor

ATTEST:

Ciara Wakefield, Deputy City Clerk

APPROVED AS TO FORM:
COUNSEL FOR YUBA CITY:

Shannon Chaffin, City Attorney
Aleshire & Wynder, LLP

ATTACHMENT 2



**QUOTATION
NO. 11391R**

**CITY OF YUBA CITY
1201 CIVIC CENTER BLVD
YUBA CITY, CA 95993-3097
SOURCEWELL MEMBER ID# 84769**

DATE: 4/26/2022
TERMS: NET 30
F.O.B: FRESNO
MFG PRODUCT: SEE BELOW
INSTALL: SEE BELOW

QTY	PART NO.	DESCRIPTION	PRICE	EXTENSION
PB LOADER CONTRACT NO. 080521-PBL SOURCEWELL CONTRACT - DISCOUNTED PRICES				
MARKET PRICE SUPPORT BODY & ACCESSORIES				
1	PBLDB-10	PB LOADER SUPPORT BODY, 15 FT 12-14 YARD, HPT53-130 CLASS 80 NTEA HOIST, 3/16" STEEL FLOOR AND TAILGATE, 10 GAUGE STEEL BALANCE, 38" SIDES, 54" FRONT AND 46" REAR, 12" SPREADER APRON, 1/4 CABSHIELD, LED LIGHTS, WIRING HARNESS & BACKUP ALARM, PUMP, CONTROLS, TANK, VALVE, MUD FLAPS, STEEL MUDGUARDS, HOT SHIFT PTO, AIR TAILGATE, PAINT BLACK, INSTALLATION		\$36,696.00
1	50502-00	PULL TARP 16' -MANUAL ASPHALT TYPE W/ ROPE HOOKS (4-PER SIDE)		\$2,867.00
1	MODS-32	SIDE FLAPS FOR PULL TARP		\$346.00
2	695-058	WHELEN 500 SERIES STROBE (LED) - MOUNTED FACING REAR	\$477.00	\$954.00
2	695-240	WHELEN LED MICRONS MCRNSA - MOUNTED IN GRILLE	\$608.00	\$1,216.00
1	8200-00	HITCH PLATE W/ D-RINGS W/ 7 WIRE ROUND PIN SOCKET		\$1,385.00
1	7050-40	45 TON PINTLE HITCH (PREMIER 270A) - MOUNTED 24-26" FROM GROUND WITH AIR BRAKE ATTACHEMENT		\$936.00
MARKET PRICE ACCESSORIES/ UPGRADES				
1		ADD FOR CHANGES TO BODY ABOVE: 10 YD CAPACITY, 32" SIDES, 40" FRONT AND 40" REAR** FLOOR MATERIAL 1/4" AR450 DOUBLE WALL SIDES HIGH LIFT TAILGATE (**IN LIEU OF STANDARD TAILGATE, INCREASES TAILGATE HEIGHT TO 40") TWO (2) DITCH GATES EITHER SIDE OF TAILGATE FOUR (4) PULL-OUT LADDERS WITH GRAB HANDLES, TWO MOUNTED DRIVER SIDE, TWO MOUNTED PASSENGER SIDE SIDE GUIDE ARMS FOR PULL TARP (BENT FOR SIDE ACCESS) SET OF TWO (2) STEEL TAILGATE SAFETY LATCHES GLAD HANDS MNT AT HITCH PLATE BODY PAINTED WHITE IN LIEU OF BLACK		\$12,685.00
1	SURCH9.0	CURRENT 9% STEEL SURCHARGE FOR SUPPORT BODY		\$3,303.00
MARKET PRICE CHASSIS				
1		2023 FREIGHTLINER M2106 CONVENTIONAL CAB CHASSIS WITH CUMMINS L9 300 HP @ 2200 RPM DIESEL ENGINE, ALLISON 3000 RDS AUTOMATIC TRANSMISSION WITH PTO PROVISION, 40,000 LB. TANDEM REAR AXLE SUSPENSION, 12,000 LB. SINGLE FRONT AXLE SUSPENSION, 50-GAL. ALUMINUM FUEL TANK, CONTINENTAL HSC3 11R22.5 16 PLY RADIAL TIRES, MAXION WHEELS 90260 STEEL WHEELS, CAB PAINTED WHITE		\$105,508.00
TOTAL:				\$165,896.00
SALES TAX (7.25%):				\$12,027.46
FREIGHT:				\$2,500.00
CA TIRE RECYLING FEE:				\$10.50
CA LICENSE FEE				\$33.00
TOTAL NET PRICE FOR ONE (1) UNIT, TAX & FREIGHT INCLUDED:				\$180,466.96
TOTAL NET PRICE FOR TWO (2) UNITS:				\$360,933.92
BUDGETARY 2023 STEEL SURCHARGE PER CHASSIS ARRIVES AFTER 12/31/22:				\$21,074.00
NOTES: 1. LEAD TIME FOR BODY PRODUCTION IS 120 DAYS, WITH AN ADDITIONAL 120-150 DAYS TO INSTALL AFTER RECEIPT OF CHASSIS AND BODY. LEAD TIME SUBJECT TO CHANGE AFTER RECEIPT TO ORDER. 2. PURCHASE ORDER MUST BE MADE OUT TO PB LOADER CORPORATION. 3. 2023 STEEL SURCHARGE WILL BE WAIVED IF ORDER IS PAID IN FULL UPON COMPLETION OF BODY AT FACTORY, BEFORE INSTALLATION ON CHASSIS. DUE TO MARKET CONDITIONS 2023 STEEL SURCHARGE IS SUBJECT TO CHANGE AT ANY TIME Delivery times are approximate.				

ATTACHMENT 3



TEREX®

CUSTOMER ORDER ACKNOWLEDGEMENT

Terex Utilities, Inc. - 3140 15th Avenue SE - Watertown, SD 57201 - Phone: 605-882-4000

Date: **5/2/2022** Sourcewell 2022 Pricing 110421-TER
 Revision #9
 Quote Number: QU16043 Unit: XTPRO 56

CITY OF YUBA CITY
 1185 MARKET STREET
 YUBA CITY, CA 95991
 (530)822-4772
 Attention: TONY JAYNE

Unit, Body & Install Price: \$150,156
Chassis: \$83,415

Grand Total Each: \$233,571

Prices are subject to change until shipment. Applicable taxes and surcharges will be added. Taxes, shipping & handling and lead times are estimates and subject to change. Quoted prices are based on total quoted package and subject to change if all items not purchased. All prices quoted are in U.S. dollars unless otherwise specified. Payment by cash or certified check only. Chassis payment is due upon chassis receipt at our facility. Quote withdrawn after 30 days.

Please ensure the accuracy of the specifications and drawings you provide. Changes made after receipt of order may incur additional charges. If you are trading equipment in, you warrant that: You have good title to the trade-in; it is free of all liens and encumbrances; all information you have provided related to the trade-in is true and correct.

Terex purchased chassis through Terex preferred International Dealer will include at no additional cost a special tow package for 12 months/unlimited mileage to nearest International Dealership for a warrantable failure. Coverage limited to \$550 per incident. Roadside assistance call 1-800-448-7825

Terex purchased chassis through Terex preferred Freightliner Dealer will include at no additional cost a special tow package for 12 months/unlimited mileage/KM extended towing coverage \$550 cap FEX applies. Roadside assistance call 1-800-FTL-HELP

Notes:

- 1) Delivery Terms are: CPT Destination
- 2) Terms: Net 30 days
- 3) Delivery days from receipt of order shall be 360 +

Buyer hereby agrees to purchase the products in this quotation, subject to acceptance by Seller. Buyer has read and agrees to Seller's Terms and Conditions of Sale.

Terex Utilities Inc.

Steve Fedt
 Sales Coordinator

Matthew Mayer
 Account Manager

⚠️WARNING Cancer and Reproductive Harm
www.P65Warnings.ca.gov

Accepted By: _____

PO Number: _____

Quantity: _____

Grand Total: _____

Date: _____

TERMS AND CONDITIONS OF SALE
TEREX SOUTH DAKOTA, INC./TEREX UTILITIES, INC.
U.S. and CANADA (except Quebec)

1. Terms and Conditions. The provision by Seller to Buyer of any Equipment or Parts (collectively referred to as “Products”) shall be exclusively governed by these Terms and Conditions of Sale (“Terms and Conditions”) and Seller’s sales order acknowledgement (collectively referred to as “Agreement”). This Agreement cancels and supersedes any and all terms and conditions previously issued by Seller and shall remain in effect unless and until superseded in writing by Seller. Acceptance of an order for Products by Seller shall be deemed to constitute a binding agreement between the parties pursuant to these Terms and Conditions and Buyer agrees that the order may not thereafter be countermanded or otherwise changed without the explicit prior written consent of Seller. No other terms and conditions shall apply, including the terms of any purchase order submitted to Seller by Buyer, whether or not objected to by Seller or whether or not such terms are inconsistent or conflict with or are in addition to these Terms and Conditions. These Terms and Conditions shall be deemed accepted by Buyer if any of the following occurs: (i) if confirmed by Buyer, (ii) if undisputed by Buyer within ten (10) days after receipt, or (iii) if Seller delivers Products to Buyer. Any communication construed as an offer by Seller and acceptance thereof is expressly limited to these Terms and Conditions. The Products are intended for industrial/commercial use by professional contractors and their trained employees and are not intended for use by consumers.

2. Terms of Payments. Payment for Products purchased by Buyer shall be made in accordance with any of the following terms, provided they have been previously arranged with and expressly approved by Seller in writing: (1) cash in advance; (2) confirmed, irrevocable letter of credit established in such amount and form and at such time and at such bank as shall be approved by Seller in respect of each order; (3) credit account purchases for which payment will be due and payable on net thirty (30) day terms, plus service and other charges applicable to past due amounts in accordance with Seller’s written notices; or (4) other payment arrangements expressly approved by Seller in writing prior to or at the time the order is placed. If any Buyer credit account purchase is not paid in accordance with Seller’s credit payment terms, in addition to any other remedies allowed in equity or by law, Seller may refuse to make further shipments without advance payment by Buyer. Nothing contained herein shall be construed as requiring Seller to sell any Products to Buyer on credit terms at any time, or prohibiting Seller from making any and all credit decisions which it, in its sole discretion, deems appropriate for Seller. Seller shall have the right, at its option, to charge interest on all amounts not paid when due and Buyer agrees to pay such interest calculated on a daily basis, from the date that payment was due until the Seller receives payment in full, at the rate of 1.5% per month or the maximum rate permitted by applicable law. Unless otherwise agreed in writing between Seller and Buyer, Seller may, in its sole discretion, increase or decrease the price of any Product, as Seller deems reasonably necessary, at any time prior to shipment and invoice Buyer for the same. If Buyer orders the chassis through Seller, the chassis payment is due upon receipt of chassis by Seller and the balance owed for the completed unit is due in accordance with agreed upon payment terms. When supplied by Buyer, Seller will inspect the chassis upon receipt and will notify Buyer of any chassis mounted components (including but not limited to fuel tanks, air tanks, battery boxes and exhaust systems) that require relocation. Buyer will be invoiced for such work upon completion of the finished Equipment.

3. Taxes and Duties. Unless otherwise noted, prices quoted do not include taxes or duties of any kind or nature. Buyer agrees that it will be responsible for filing all tax returns and paying applicable tax, duty, export preparation charge and export documentation charge resulting from the purchase of the Products. In addition, in the event any other similar tax is determined to apply to Buyer’s purchase of the Products from Seller, Buyer agrees to indemnify and hold Seller harmless from and against any and all such other similar taxes, duties and fees. All prices quoted are U.S. dollars unless otherwise specified. The amount of any present or future taxes applicable to the sale, transfer, lease or use of the Products shall be paid by Buyer; or in lieu thereof, Buyer shall provide Seller with a tax exemption certificate satisfactory to the applicable taxing authority proving that no such tax is due and payable upon such sale, transfer, lease or use.

4. Title, Property, Risk and Delivery. Unless otherwise stated in writing, for all intra-continental United States shipments, all prices and delivery are FCA, point of manufacture (Incoterms 2020); for all other shipments, all prices and delivery are FAS, named port of shipment (Incoterms 2020). Title and all risk of loss or damage to Products shall pass to Buyer upon delivery, as per Incoterms 2020. Any claims for loss, damage or delay in transit must be entered and prosecuted by the Buyer directly with the carrier, who is hereby declared to be the agent of the Buyer. Seller shall not be liable for any delay in performance of this agreement or delivery of the Products, or for any damages suffered by Buyer by reason of delay, when the delay is caused, directly or indirectly, by a force majeure event described in Section 20 herein or any other cause beyond Seller’s control. Claims for shortages in shipments shall be deemed waived and released by Buyer unless made in writing within five (5) days after Buyer’s receipt of shipment. Seller’s responsibility for shipment shall cease upon delivery of the Products to the place of shipment, and all claims occurring thereafter shall be made to or against the carrier by Buyer. Delivery shall generally be 240 to 270 days after receipt by Seller of a signed Order, provided that, where applicable: (1) Seller receives the chassis a minimum of 90 days prior to scheduled delivery, (2) drawings are timely sent by Buyer and the approved drawings are returned to Seller by Buyer by the requested date, (3) all vendor-supplied components and Buyer-supplied accessories are received by Seller by the date necessary to comply with scheduled delivery. Seller shall not be liable for any delay in performance of this agreement or delivery of the Products, or for any damages suffered by Buyer by reason of delay, when the delay is caused, directly or indirectly, by a force majeure event described in Section 20 herein or any other cause beyond

Seller's control. Claims for shortages in shipments shall be deemed waived and released by Buyer unless made in writing within fifteen (15) days after Buyer's receipt of shipment. Seller's responsibility for shipment shall cease upon delivery of the Parts and or Equipment to the place of shipment, and all claims occurring thereafter shall be made to or against the carrier by Buyer.

5. Delays Caused By Buyer. In the event of a delay in shipment or delivery due to delay by Buyer in furnishing delivery instructions, arranging a method of payment satisfactory to Seller, submitting valid import permits or licenses, or any other delay caused by Buyer or at Buyer's request, if the Products are not shipped or delivered within five (5) days from the first date they are ready to be shipped or delivered, then Seller shall be entitled to charge, as compensation, any additional costs incurred related to such delay. If the Products are not shipped or delivered by the date which is ten (10) days from the first date they are ready to be shipped or delivered, then Buyer's order shall be deemed cancelled and Seller may, in its sole discretion, sell such Products to another buyer without any liability or responsibility to Buyer whatsoever. Seller shall have the right to keep payments on account already received from Buyer, and the difference between the sales price (increased by any other and all further costs, including but not limited to attorney's fees and expenses, storage and other costs, and interest accrued thereon) and the price received from another buyer shall constitute a debt of Buyer and bear interest at the same rate set forth in Section 2 herein. Seller shall be entitled to claim for any further damages suffered as a consequence of Buyer's breach of its obligations hereunder.

6. Cancellation. Prior to delivery to place of shipment, a Product order may be cancelled only with Seller's prior consent and upon terms indemnifying Seller from all resulting losses and damages. Seller shall have the right to cancel and refuse to complete a Product order if any term and/or condition governing this agreement is not complied with by Buyer. In the event of cancellation by Seller, or in the event Seller consents to a request by Buyer to stop work or to cancel the whole or any part of any order, Buyer shall, in the event that Seller asks Buyer to do so, make reimbursement to Seller, as follows: (i) any and all work that can be completed within thirty (30) days from date of notification to stop work on account of cancellation shall be completed, shipped and paid in full; and (ii) for work in progress and any materials and supplies procured or for which definite commitments have been made by Seller in connection with the order, Buyer shall pay such sums as may be required to fully compensate Seller for actual costs incurred, plus fifteen percent (15%). Buyer may not cancel any order after Seller's delivery to place of shipment. Orders for "Special" Equipment may not be cancelled after acceptance, except by Seller. Items of "Special" Equipment are those that differ from standard Seller specifications, have a limited market, or incorporate specifications that have been determined for a specific application. Determination of whether an item of Equipment is "Special" shall be made by Seller in its sole discretion.

7. Inspection and Acceptance. Buyer agrees that it shall inspect the Products immediately after receipt and promptly (in no event later than fifteen (15) days after receipt) notify Seller in writing of any non-conformity or defect. Buyer further agrees that failure to give such prompt notice or the commercial use of the Products shall constitute acceptance. Acceptance shall be final and Buyer waives the right to revoke acceptance for any reason, whether or not known by Buyer at the time of such acceptance. The giving of any such notice by Buyer shall automatically cause the provisions of Seller's warranty to apply and govern the rights, obligations and liabilities of the parties with respect to such nonconformity or defect, provided under no circumstances shall rejection give rise to any liability of Seller for incidental or consequential damages or losses of any kind. Seller shall not be bound by any agent's, employee's or any other representation, promise or inducement not set forth herein. Seller's catalogues, technical circulars, price lists, illustrations, drawings and any other similar literature are for Buyer's general guidance only and the particulars contained in them shall not constitute representations by Seller and Seller shall not be bound by them.

8. Warranty for New Products. Seller warrants its new Equipment and Parts manufactured and sold worldwide, to be free, under normal use and service, of any defects in material or workmanship for a period of twelve (12) months from the date of delivery (as limited by Seller's Limited Product Warranty); provided that Buyer sends Seller written notice of the defect within thirty (30) days of its discovery and establishes that: (i) the Equipment has been operated and maintained in strict compliance with Seller's operating and maintenance manuals ; and (ii) the defect did not result in any manner from the intentional or negligent action or inaction of Buyer, its agents or employees and (2) a new machine registration certificate has been completed, signed and delivered to the Seller within thirty (30) days of the Equipment's "in-service" date. If requested by Seller, Buyer must return any defective Product to Seller's manufacturing facility, or other location designated by Seller, for inspection, and if Buyer cannot establish that conditions (i) and (ii) above have been met, then this warranty shall not cover the alleged defect. Failure to give written notice of defect within such period shall be a waiver of this warranty and any assistance rendered thereafter shall not extend or revive it. Accessories, assemblies and components included in the Products of Seller, which are not manufactured by Seller, are subject to the warranty of their respective manufacturers. This warranty shall not cover any item on which serial numbers have been altered, defaced or removed. Maintenance and wear parts are not covered by this warranty and are the sole maintenance responsibility of Buyer. This warranty is limited to the original purchaser or end-user if sold to a distributor, and is not assignable or otherwise transferable without written agreement of Seller. **THIS WARRANTY IS EXPRESSLY IN LIEU OF AND EXCLUDES ALL OTHER WARRANTIES, EXPRESS OR IMPLIED (INCLUDING THE WARRANTIES OF MERCHANTABILITY AND FITNESS FOR A PARTICULAR PURPOSE) AND ALL OTHER OBLIGATIONS OR LIABILITY ON SELLER'S PART. THERE ARE NO WARRANTIES THAT EXTEND BEYOND THE LIMITED WARRANTY CONTAINED HEREIN.** Seller neither assumes nor authorizes any other person to assume for Seller any other liability in connection with the sale of Seller's Products. This

warranty shall not apply to any of Seller's Products or any part thereof which has been subject to misuse, alteration, abuse, negligence, accident, acts of God or sabotage. No action by either party shall operate to extend or revive this limited warranty without prior written consent of Seller.

9. Warranty for Used Equipment. Used Equipment sold hereunder is sold on an "AS IS, WHERE IS, WITH ALL FAULTS" BASIS WITH NO WARRANTIES WHATSOEVER, EXCEPT AS TO TITLE, UNLESS OTHERWISE SPECIFICALLY AGREED IN WRITING BY BUYER AND SELLER. SELLER ASSUMES NO RESPONSIBILITY FOR THE CONDITION, SAFETY, LEGAL COMPLIANCE, OR USABILITY OF THE USED EQUIPMENT AND MAKES NO REPRESENTATION OR WARRANTY, EXPRESS OR IMPLIED, WITH RESPECT TO THE USED EQUIPMENT INCLUDING, WITHOUT LIMITATION, ANY IMPLIED WARRANTY OF MERCHANTABILITY OR FITNESS FOR A PARTICULAR PURPOSE. SELLER MAKES NO REPRESENTATION OR WARRANTY REGARDING THE CONDITION OF THE USED EQUIPMENT, NOR THE SUFFICIENCY OF ANY WARNINGS, INSTRUCTIONS OR MANUALS PROVIDED WITH THE USED EQUIPMENT. Seller recommends and Buyer acknowledges that Buyer should contact the original manufacturer to obtain all available information for the used Equipment, including but not limited to product manuals, warnings, safety bulletins, recall notices, and instructional placards before using the used Equipment. Seller shall not be responsible for providing such information. Buyer agrees not to assert any claims against Seller with respect to the used Equipment or its use. Buyer agrees that it shall inspect the used Equipment prior to issuance of a purchase order for such Equipment and acknowledges that it is not relying upon any photographs, images, videos, representations, statements or other assertions made by Seller with respect to the used Equipment's condition, but is relying upon its own knowledge and/or inspection of the used Equipment.

10. Remedies for Breach. IN THE EVENT OF ANY BREACH OF THE WARRANTY BY SELLER, THE PARTIES AGREE THAT SELLER'S LIABILITY SHALL BE LIMITED EXCLUSIVELY TO THE REMEDIES OF REPAIR OR REPLACEMENT (AT SELLER'S SOLE DISCRETION) OF ANY DEFECTIVE EQUIPMENT COVERED BY THE WARRANTY. In no event shall any repair or replacement of any defective equipment covered by the Seller's warranty extend the length of the warranty beyond the period specified in Section 8 herein.

11. Limitation of Liability. NOTWITHSTANDING ANYTHING CONTAINED IN THIS AGREEMENT TO THE CONTRARY, SELLER AND ITS AFFILIATES SHALL NOT BE LIABLE FOR, AND SPECIFICALLY DISCLAIM, ANY LIABILITY FOR ANY: (A) LOST PROFITS AND/OR BUSINESS INTERRUPTION (WHETHER DIRECT OR INDIRECT); AND (B) INDIRECT, INCIDENTAL, CONSEQUENTIAL (WHETHER DIRECT OR INDIRECT) OR OTHER DAMAGES OR LOSSES OF ANY KIND WHATSOEVER, including, without limitation, labor costs, lost profits, loss of use of other equipment, third party repairs, personal injury, emotional or mental distress, improper performance or work, penalties of any kind, loss of service of personnel, or failure of Products to comply with any federal, state, provincial or local laws, regardless of whether arising from a breach of contract, or warranty, legal claims or otherwise. **Nothing in this Section shall operate to exclude Seller's liability for death or personal injury when directly related to Seller's negligent act or omission.**

12. Limitation of Actions. Any action for breach of this agreement must be commenced within one (1) year after the cause of action has accrued.

13. Specification Changes. In the event Seller incurs additional expense because of changes in specifications or drawings previously approved by Buyer, or in the event Seller is required to modify the ordered Equipment, perform any additional work or supply any additional Products, the additional expense shall be added to the purchase price. Buyer must submit to Seller a revised purchase order specifying any and all requested changes. Upon receipt of Buyer's revised purchase order, Seller shall have the right, in its sole discretion, to accept or reject any changes in specifications requested by Buyer.

14. Trade-in Offers. Trade-in offers are subject to Seller's inspection and acceptance of the equipment, which must have been maintained to U.S. Department of Transportation operating and safety standards. All accessories on the equipment, including without limitation jibs, winches, pintle hooks and trailer connectors, must remain with the equipment unless otherwise agreed by Seller and Buyer in writing. Seller reserves the right to cancel any trade-in offers or agreements if these conditions are not met, or if Buyer has misrepresented any information about the trade-in unit.

15. Insurance. Until the purchase price of any Products is paid in full, the Buyer shall provide and maintain insurance equal to the total value of the Equipment delivered hereunder against customary casualties and risks; including, but not limited to fire and explosion, and shall also insure against liability for accidents and injuries to the public or to employees, in the names of Seller and Buyer as their interest may appear, and in an amount satisfactory to Seller. If the Buyer fails to provide such insurance, it then becomes the Buyer's responsibility to notify the Seller so that the Seller may provide same; and the cost thereof shall be added to the contract price. All loss resulting from the failure to affect such insurance shall be assumed by the Buyer.

16. Patents, Copyrights, Trademarks, Confidentiality. No license or other rights under any patents, copyrights or trademarks owned or controlled by Seller or under which Seller is licensed are granted to Buyer or implied by the sale of Products hereunder. Buyer shall not identify as genuine products of Seller products purchased hereunder which Buyer has treated, modified or altered in any way, nor shall Buyer use Seller's trademarks to identify such products; provided, however, that Buyer may identify such products as utilizing, containing or having been manufactured from genuine products

of Seller as treated, modified or altered by Buyer or Buyer's representative, upon prior written approval of Seller. All plans, photographs, designs, drawings, blueprints, manuals, specifications and other documents relating to the business of Seller ("Information") shall be and remain the exclusive property of Seller and shall be treated by Buyer as confidential information and not disclosed, given, loaned, exhibited, sold or transferred to any third party without Seller's prior written approval; provided, however, that these restrictions shall not apply to Information that Buyer can demonstrate: (a) at the time of disclosure, is generally known to the public other than as a result of a breach of this Agreement by Buyer; or (b) is already in Buyer's possession at the time of disclosure by from a third party having a right to impart such Information.

17. Default and Seller's Remedies. In the event of default by Buyer, all unpaid sums and installments owed to Seller, shall, at Seller's sole option, become immediately due and payable without notice of any kind to Buyer. In addition to its right of acceleration, Seller may pursue any and all remedies allowed by law or in equity, including but not limited to any and all remedies available to it under the Delaware Uniform Commercial Code. In addition to the foregoing, and not in limitation thereof, Seller shall have the right to set off any credits or amounts owed to Buyer against any amounts owed by Buyer to Seller.

18. Indemnification by Buyer. Buyer hereby agrees to indemnify, release, defend and hold harmless Seller, its directors, officers, employees, agents, representatives, successors, and assigns against any and all suits, actions or proceedings at law or in equity (including the costs, expenses and reasonable attorney's fees incurred in connection with the defense of any such matter) and from any and all claims demands, losses, judgments, damages, costs, expenses or liabilities, to any person whatsoever (including Buyer's and Seller's employees or any third party), or damage to any property (including Buyer's property) arising out of or in any way connected with the performance or the furnishing of Products under this agreement, regardless of whether any act, omission, negligence (including any act, omission or negligence, relating to the manufacture, design, repair, erection, service or installation of or warnings made or lack thereof with respect to any Products furnished hereunder) of Seller, its directors, officers, employees, agents, representatives, successors or assigns caused or contributed thereto. If Buyer fails to fulfill any of its obligations under this paragraph or this agreement, Buyer agrees to pay Seller all costs, expenses and attorney's fees incurred by Seller to establish or enforce Seller's rights. The provisions of this paragraph are in addition to any other rights or obligations set forth in this agreement.

19. Installation. Unless otherwise expressly agreed in writing, Buyer shall be solely responsible for the installation and erection of the Products purchased. Although Seller may in some cases provide a serviceman, data and drawings to aid Buyer with installation or start-up, Seller assumes no responsibility for proper installation or support of any Products when installed and disclaims any express or implied warranties with respect to such installation and support. Notwithstanding whether data and drawings are provided or a serviceman aids in the installation, Buyer shall indemnify and hold Seller harmless and at Seller's request, defend Seller from all claims, demands or legal proceedings (including the costs, expenses and reasonable attorney's fees incurred in connection with the defense of any such matter) which may be made or brought against Seller in connection with damage or personal injury arising out of said installation or start-up.

20. Force Majeure. Seller shall not be liable to Buyer or be deemed to be in breach of this agreement by reason of any delay in performing, or any failure to perform, any of Seller's obligations in relation to the Products if the delay or failure was due to any cause beyond the reasonable control of Seller including (without limitation) strike, lockout, riot, civil commotion, fire, accident, explosion, tempest, act of God, war, epidemic, stoppage of transport, terrorist activity, supply shortage or changes in government, governmental agency, laws, regulations or administrative practices.

21. Anti-Corruption; Export Controls; No Boycotts. Buyer agrees that it shall, and that any party retained or paid by the Buyer ("Retained Party") shall, comply with all applicable laws including, but not limited to, laws prohibiting public corruption and commercial bribery. Buyer further agrees that it shall, and that any Retained Party shall, comply with all applicable export controls, economic sanctions, embargoes and regulations regarding the export, re-export, shipment, distribution and/or sale of Products, technology, information or warranty related services. Buyer further agrees that it shall not, and any Retained Party shall not, export or re-export Products, technology, information or warranty related services directly or with its knowledge indirectly into Iran, Sudan, Cuba, Syria, North Korea, the Crimea Region of the Ukraine or Russia without Buyer first obtaining written approval from Seller. Failure to comply strictly with this section and all applicable laws, regulations and licensing/approval requirements shall be grounds for immediate termination of this agreement by Seller. Notwithstanding anything to the contrary contained in any agreement between the Buyer and Seller or in any other document or agreement relating to the Products sold hereunder, Seller will not comply with requests related to the boycott of any country or other jurisdiction, except to the extent such boycott is required by or otherwise not inconsistent with United States law.

22. Telematics. If a telematics system is included with the Equipment, the telematics system is administered by a third party ("Teleservice Provider") and collects a range of operational data about the Equipment including, but not limited to, usage, performance and reliability. Buyer consents to Seller's obtaining such data from the Teleservice Provider for warranty, product improvement, marketing and customer support purposes and to Seller's management and reporting of data (personal and non-personal) about the Equipment including, but not limited to, fuel consumption, up/down times, operation, defects, parts replacement, movement and location. Buyer shall, to the extent required by applicable law, obtain consent from its customers and/or any third party for Seller and/or third parties to provide teleservices and data to Buyer. Buyer shall

comply with all applicable laws relating to the provision of teleservices. Buyer agrees to be bound by the current version of the Terex Telematics Terms of Use at <https://www.terex.com/en/products/telematics-tou>.

23. Construction and Severability. These Terms and Conditions of Sale constitute the entire agreement between the parties regarding the subject matter hereof and shall be construed and enforced in accordance with the laws of Delaware. The United Nations Convention on Contracts for the International Sale of Goods (1980) (CISG) shall not apply. The invalidity or unenforceability of any provisions of this agreement shall not affect any other provision and this agreement shall be construed in all respects as if such invalid or unenforceable provision were omitted.

24. Jurisdiction. The parties agree that the proper and exclusive forum and venue in all legal actions brought to enforce or construe any provisions herein shall be in United States District Court, District of Delaware or, if federal jurisdiction is lacking in such action, in New Castle County Superior Court in Delaware.

25. No Assignment. No rights arising under this agreement may be assigned by the Buyer unless expressly agreed to in writing by the Seller.

26. No Set-off. Buyer shall have no right to set-off any amounts it may owe Seller against amounts Seller may owe Buyer under this or any other agreement between Buyer and Seller.

27. Miscellaneous. Buyer represents that: (i) it is solvent and has the financial ability to pay for the Equipment and Parts purchased hereunder and (ii) it has all requisite right, power and authority to perform its obligations under this agreement.

Buyer's Initials: _____



LIMITED PRODUCT WARRANTY

TEREX Utilities, Inc. and TEREX South Dakota, Inc. (each a "Seller"), as to the equipment manufactured by each respective company, warrants its new equipment and parts manufactured and sold worldwide to be free, under normal use and service, of any defects in manufacture or materials for a period of **12 months from date of delivery to the first end user, but in no event longer than 18 months from date of shipment from the factory**; provided that (1) Seller receives written notice of the defect within thirty (30) days of its discovery and Buyer establishes that (i) the equipment has been maintained and operated within the limits of rated and normal usage; and (ii) the defect did not result in any manner from the intentional or negligent action or inaction by Buyer, its agents or employees, and (2) a new machine registration certificate has been completed and received by Seller within thirty (30) days of the equipment's "in-service" date. If requested by Seller, Buyer must return the defective equipment to Seller's manufacturing facility, or other location designated by Seller, for inspection, and if Buyer cannot establish that conditions (1) (i) and (1) (ii) above have been met, then this warranty shall not cover the alleged defect.

Seller's obligation and liability under this warranty is expressly limited to, at Seller's sole option, repairing or replacing, with new or remanufactured parts or components, any part which appears to Seller upon inspection to have been defective in material or workmanship. Such parts shall be provided at no cost to the owner, FOB Seller's parts facility (Incoterms 2010). If requested by Seller, components or parts for which a warranty claim is made shall be returned to Seller at a location designated by Seller. All components and parts replaced under this warranty become the property of Seller. This warranty shall be null and void if parts (including wear parts) or attachments other than genuine OEM Seller parts or approved attachments are used in or attached to the equipment.

Accessories, assemblies and components included in Seller's equipment, which are not manufactured by Seller, are subject to the warranty of their respective manufacturers. Normal maintenance, adjustments, or maintenance/wear parts, are not covered by this warranty and are the sole maintenance responsibility of Buyer.

The following structural members have a lifetime parts only warranty for the original Buyer after date of shipment from Seller: sub frame, pedestal, turntable, and boom. Replacement of fiberglass jibs, seals, gaskets, hoses, and exterior coating is not covered under the lifetime warranty. The lifetime warranty requires an annual service inspection of the equipment by an authorized distributor of Seller. The sub frame, pedestal, turntable, and boom shall have a 5 year parts only warranty if the annual service inspection is performed by an approved entity other than an authorized distributor of Seller. All replacement parts must be genuine OEM Seller parts.

SELLER MAKES NO OTHER WARRANTY, EXPRESS OR IMPLIED, AND MAKES NO WARRANTY OF MERCHANTABILITY OR FITNESS FOR ANY PARTICULAR PURPOSE, AS TO THE EQUIPMENT AND PARTS IT SUPPLIES.

No employee or representative of Seller is authorized to modify this warranty unless such modification is made in writing and signed by an authorized officer of Seller. Seller's warranty is continuous for the stated period, and "stopping and restarting" such period is not permitted.

Seller's obligation under this warranty shall not include duty, taxes, environmental fees, including without limitation, disposal or handling of tires, batteries, petrochemical items, or any other charges whatsoever. Seller shall not be liable for indirect, incidental, or consequential damages, even if advised of the possibility of such damages.

Improper maintenance, improper use, abuse, improper storage, operation beyond rated capacity, operation after discovery of defective or worn parts, accident, sabotage or alteration or repair of the equipment by persons not authorized by Seller shall render this warranty null and void. Seller reserves the right to inspect the installation of the product and review maintenance procedures to determine if the failure is covered under this warranty.

Parts Warranty: Seller warrants the parts ordered from the Seller to be free of defects in materials or workmanship for either (1) a period of 12 months after date of shipment from the factory, or (2) the balance of the remaining new equipment warranty, whichever occurs first. With respect to parts ordered from Seller for equipment for which the warranty has expired, Seller warrants such parts to be free of defects in materials or workmanship for a period of 12 months after date of shipment from the factory.

NO TRANSFERABILITY OF WARRANTY: This warranty is limited to the original purchaser or original end-user if sold to a distributor, and is not assignable or otherwise transferable without the written agreement of Seller.

ITEMS NOT COVERED BY WARRANTY

The following listed items, which are not exhaustive, are **NOT** covered under this warranty:

1. Items sold by any individual, corporation, partnership or any other organization or legal entity that is not authorized by Seller to distribute its equipment.
2. Inbound freight, duty and taxes for replacement components or outbound freight, duty, and taxes for any part requested as a warranty return.
3. Components which are not manufactured by Seller or its affiliates. Such components may include, but are not limited to, chassis, engines, batteries, tires, customer-supplied products, transmissions, air compressors, and axles.
4. Replacement of a complete assembly that is field repairable by the replacement or repair of defective part(s) within the assembly. Seller has the option to repair or replace any defective part or assembly.
5. Wear parts and maintenance services including, but not limited to: lamps, lenses, seals, gaskets, hoses, filters, breathers, belts, nozzles, friction plates, glass, clutch and brake linings, wire rope, nuts and fittings, exterior coatings, proper tightening of bolts, adding or replacing of fluids, adjustments of any kind, services, inspections, diagnostic time, travel time and supplies such as hand cleaners, towels and lubricants.
6. Damage caused by carrier handling. Any such claim for damage should be filed immediately with the respective carrier.
7. Repairs, work required or parts exposed as the result of age, storage, weathering, lack of use, demonstration use, or use for transportation of corrosive chemicals.
8. Damage resulting to the equipment or parts should the owner or operator continue to operate the equipment after it has been noted that a failure has occurred.
9. Damage caused by, or labor or other costs related to, work performed by personnel not authorized by Seller to service the equipment.

IN NO EVENT SHALL SELLER, OR ANY AFFILIATE, SUBSIDIARY OR DIVISION THEREOF BE LIABLE FOR INDIRECT, INCIDENTAL OR CONSEQUENTIAL DAMAGES OR LOSSES RESULTING FROM ANY BREACH OF WARRANTY, REPRESENTATION OR CONDITION, EXPRESS OR IMPLIED, OR ANY TERMS OF THIS WARRANTY, OR ANY BREACH OF ANY DUTY OR OBLIGATION IMPOSED BY STATUTE, CONTRACT, TORT, COMMON LAW OR OTHERWISE (WHETHER OR NOT CAUSED BY THE NEGLIGENCE OF THE SELLER, ITS EMPLOYEES, AGENTS OR OTHERWISE), INCLUDING, WITHOUT LIMITATION, LOSS OF USE, LOST PROFITS OR REVENUES, LABOR OR EMPLOYMENT COSTS, LOSS OF USE OF OTHER EQUIPMENT, DOWNTIME OR HIRE CHARGES, THIRD PARTY REPAIRS, IMPROPER PERFORMANCE OR WORK, LOSS OF SERVICE OF PERSONNEL, LOSS OF CONTRACTOR OPPORTUNITY AND PENALTIES OF ANY KIND, PERSONAL INJURY, EMOTIONAL OR MENTAL DISTRESS, OR FAILURE OF EQUIPMENT TO COMPLY WITH ANY APPLICABLE LAWS. The Seller's liability to the Buyer shall not in any event exceed the purchase price of the equipment.

THIS WARRANTY IS EXPRESSLY IN LIEU OF AND EXCLUDES ALL OTHER WARRANTIES, REPRESENTATIONS AND CONDITIONS, EXPRESS OR IMPLIED AND ALL OTHER STATUTORY, CONTRACTUAL, TORTIOUS AND COMMON LAW OBLIGATIONS OR LIABILITY ON SELLER'S PART ARE HEREBY EXPRESSLY EXCLUDED TO THE MAXIMUM EXTENT PERMITTED BY LAW. THERE ARE NO WARRANTIES THAT EXTEND BEYOND THE LIMITED WARRANTY CONTAINED HEREIN. Seller neither assumes nor authorizes any other person to assume for Seller any other liability in connection with the sale of Seller's equipment. In the event that any provision of this warranty is held unenforceable for any reason, the remaining provisions shall remain in full force and effect.



Terex Utilities, Inc.
3140 15th Ave SE, Watertown, SD 57201
Phone: 605-882-4000 Fax: 605-882-1842

04/28/2022

CITY OF YUBA CITY
1185 MARKET STREET
YUBA CITY, CA 95991
Attention: TONY JAYNE

Phone: (530)822-4772

Qty. Description

UNIT

- 1 One (1) new Terex Hi-Ranger XT PRO 56 insulated overcenter aerial device providing a working height of 61.0 ft (18.6 m) and a side reach of 41.5 ft (12.6 m) non-overcenter and 45.6 ft (13.9 m) overcenter.

Design Criteria:

* Design criteria is in accordance with current industry and engineering standards applicable and accepted for structural and hydraulic design.

Boom Tip:

Upper Controls: "Control-Plus" single stick controller.

Maintenance free chain.

Manual Platform Tilt Release:

- * Tilts perpendicular to the boom.
- * Allows the platform to be horizontally tilted for rescue or clean out.

Dual Hydraulic Tool Outlets At Platform:

- * Dual hydraulic tool outlets at platform to accommodate two (2) open center hydraulic tools.
- * Tools cannot operate simultaneously.
- * Includes relief to limit pressure to 2250 PSI.
- * Flow is adjustable.

Lower Boom:

- * Filament wound high strength fiberglass insert providing an insulation gap.
- * The lower boom is supported when stored by a boom rest.

Upper Boom:

- * Filament wound tapered fiberglass boom providing a clear span insulation gap.

Continuous & Unrestricted Rotation:

- * A hydraulic rotary manifold provides a rotating oil distribution system for continuous and unrestricted rotation.
- * Self-locking worm gear rotation drive is provided and equipped with bi-directional motor.
- * A 4-channel electric collector ring is provided.

Lower Controls:

Qty. Description

- * Individual control levers are provided and located in an accessible location on the turntable.
- * An upper/lower control selector provides override of platform controls.

Outrigger Interlock:

- * To operate the boom the outriggers must be extended.

Pedestal:

- * The pedestal is designed with access for maintenance of hydraulic plumbing.

Rotation Bearing:

- * The rotation bearing is a heavy duty "shear-ball" bearing with external gear teeth utilizing polished alloy steel balls.
- * Both the inner and outer races are machined from high-strength alloy steel and are heat treated to provide maximum life.
- * High-strength, grade 8 bolts attach the inner and outer races to the pedestal and turntable.

ANSI Rating:

Aerial device is designed as a Category C machine in accordance and is dielectrically tested and rated for operation on systems up to 46 Kv phase to phase per ANSI/SIA A92.2-2015

Hydraulic System:

- * Full pressure, open center hydraulic system.
- * A external 33 gallon hydraulic oil reservoir is provided with a 60 mesh filter screen, baffles, 100 mesh suction screen with bypass, clean-out access hole, dipstick and shut off valve.
- * A 10 micron return line filter located in oil reservoir.
- * An in-line relief is also provided.
- * Hydraulic hoses are equipped with swaged hose fittings.

Miscellaneous:

- * All metallic components of the complete aerial device are powder coat white.
- * The fiberglass upper boom, lower boom insert, and platforms are white.
- * Two complete manuals providing operation and maintenance procedures, and a replacement parts listing.
- * Warning decals are provided with unit.

1 Pedestal and Outriggers Assembly, Split Mount.

- * For behind the cab mount units.
- * Booms not installed on the pedestal/outriggers prior to shipping.
- * One set of (9283) outriggers welded and assembled to pedestal.
- * Outrigger controls and Chip box dump control located on side of pedestal.
- * Outrigger moving alarm, outrigger and chip box harness and switches shipped loose

1 Platform 24" x 24" x 40":

- * One curbside mounted fiberglass platform with a rated capacity of 400 lbs.
- * Includes one (1) outside access step with slip-resistant surface.

1 A safety harness with lanyard is provided for fall arrest.**1 A padded saddle rest provides platform support during road travel.**

Qty. Description

1 Insulated Platform Liner For 24" x 24" x 40" Platform:
* Tested at 50 KV AC.

1 Vinyl Platform Cover For 24" x 24" Platform:
* Waterproof with internal elastic cord around edge.

1 Tie down kit.

1 Engine Stop/Start controlled at platform and lower controls.

Auxiliary Let Down for use with Open Center Hydraulics:

* Allows for the descent of the boom (platform) in the most direct manner for a time limited by the duty cycle of the electric motor.

*Includes 12 volt electric motor for use on a 12 volt chassis.

Note: This includes a switch for activation at pedestal for electric or air function.

1 Terex Advanced Chassis Controller:

* Multiplexed system to include: Controller, LCD Screen, Manual and Schematics.

* Standard Options: Diagnostics, Status Screens, Event Log, Hours Meter, Selectable Button Labels, System Alerts and System Test.

* Programmable settings allow installer to customize/select options need for their application.

* Back-up Camera ready.

* Screw terminal-type connections and enclosure to cover connections.

* Recommended on Class 6 and above chassis with multiple outputs

* The PTO hour is standard. The engine hour meter is standard (When available). This is a message we get from the truck Data link. All trucks except Ford give us the Engine hours. So if it's a Ford, we just display PTO hours.

1 Pump: Fixed Gear and bi-directional
* 8 GPM at 2750 PSI at 1200 RPM

** ALTERED FROM STANDARD **

1 .

1 American flag displayed on unit.

1 Factory Warranty

BODY, INSTALLATION

** BODY INFORMATION **

1 Chipper Body Package:

* As per the attached Chipper Body Specifications.

** BODY INFORMATION **

1 Terex Install of Chipper Body Package:

1 Install Aerial Device Behind Cab And Install All Associated Components:

Qty. Description

- * Final test and inspect completed unit including stability and dielectric testing per manufacturers requirements.
- 1 Hose and fittings to connect the hydraulic system from the oil reservoir to the pump and unit.
- 1 Platform rest, bottom base
- 1 Power take off with indicator light for automatic transmission.
- 1 DOT Inspection.
- 1 Set chassis parameters.
- 1 Back-up alarm to sound when the vehicle is shifted into reverse.
- 2 Laminated wood outrigger pad 24" x 24" x 2-1/4" with rope handle.
 - * Includes outrigger pad storage.
 - * Locate (1) under each side of Body Compartments.
- 2 Chain style retainer
- 2 Rubber wheel chocks with eye bolt.
- 2 Wheel chock bracket, single for mounting under the body.
 - * Locate under Curbside of Chipper Body - Front and Rear of Rear Axle.
- 2 Chain style retainer
- 2 Cone holder bracket, fold down type with base.
 - * Locate (1) on each Outrigger.
- 1 Grab handles as necessary for 3-point contact.
- 2 Mud flap with logo 30" tall.
 - Note: Trim As-Required.
- 1 A mounting kit for under 45" flatbed frame height for a pair of mud flaps.
- 1 Tree trimmer cab guard constructed of tubing and heavy duty expanded metal, painted black. Includes curb side access steps to top of cab guard
 - * Top of Cab Guard to be covered with Steel Treadplate -
 - Treadplate Gauge to be determined on Approval Drawings.
 - * Change to Curbside Staircase Gripstrut Access Steps.

Qty. Description

- 1 Channel bumper and skirt required for mounting a cab guard.
- 1 Chipper Body Lighting Wiring:
 - * Connect Body Vendor Supplied Chipper Body Lighting Wiring to Chassis and -- Terex Chassis Controller Wiring.
- 1 Lighted license plate bracket kit with LED light.
- 1 Peterson Clearance Light Kit with 2.50" Amber, LED.
- 4 12 volt outlet, cigarette electrical style.
 - * Locate (1) in at each Corner of Cab Guard - Near Golight Mounts.
- 1 Whelen 4 corner LED, Amber Strobe Light Kit with 4" grommets.
 - *Wired into On/Off switch in cab.
 - * Locate (2) at Front under Cab Guard.
 - * Locate (2) at Rear Upper Corners of Chipper Body.
- 2 Cab guard strobe mounting.
- 2 Golight 7901 spotlight, portable, programmable wireless remote, suction cup & magnetic mount shoe, 15' cord w/cigarette plug and white in color.
 - * Ship Loose.
- 4 Bracket for spotlight mounting.
 - * Plate for Magnetic Mount Golight(s).
 - * Locate (1) on each Corner of Cab Guard.
- 1 Whelen TAM-65 arrow directional LED light stick, 36" long, 6-lamp.
 - * Locate on Top Rear of Chipper Body - Centered.
- 1 Guard for Whelen Traffic Advisor:
 - * Terex PN: TBD.
- 1 Tekonsha Voyager electric brake control.
- 1 15 ton pintle hook:

Qty. Description

* Safety chain eyes.

"Pintle hook brackets and attachment methods are designed to meet the associated pintle hook ratings. They are not designed for recovery purposes. If recovery attachments are required, please order the appropriate tow eyes."

- 1 ICC rear bumper.
- 1 7-blade trailer socket. (RV style)
- 1 Heat shields, as required to protect hydraulic system from exhaust.
- 1 Oil tank mounting for external reservoirs.
- 45 Fill with Hydraulic oil for general purpose use.
 - * Refer to the product maintenance manual for specific type to be used.
- 1 Modify to Auxiliary Tool Outlet Hydraulic Quick Couplers:
 - * Add 90-Degree Elbow Fittings to (1) Set of Quick Couplers.
 - * Terex PNs: TBD.
- 1 Fairmont 43178 Hydraulic Long Reach Chain Saw:
 - * 62.5" Long Reach with 13" cutting capacity.
 - * Rotate trigger spool for open or closed center systems.
- 1 8' of non-conductive hose with couplers.
- 1 Scabbard for chain saw, plastic that mounts to the rim of platform.
- 1 Boom Mount Chain Saw Scabbard:
 - * Model #ARBSC.
 - * Includes Scabbard / Handle Rack & (3) Ratchet Straps.
 - * Terex PN: TBD.
- 1 Safety Kit consists of the following:
 - * 5-lb ABC fire extinguisher with bracket.
 - * James King triangle reflector kit.
- 2 Level indicator, Rieker inclinometer, +/- 5 Degrees.
 - * Locate near Outrigger Controls - (1) Side to Side & (1) Fore & Aft.
- 1 Rear view vision 2.5" round red marker light camera & 5" monitor system.
- 1 Paint body floor with non-skid paint.
 - * Include Cab Guard.

Qty. Description

1 Paint compartment top with non-skid paint.

1 Paint cab guard one color.

* Note: specify color

* WHITE to match Chassis Cab.

CHASSIS

1 Freightliner M2 106 4x2 (Spec # 80)

* 33,000 lbs GVWR

* Wheelbase 189", CA 123", axle to frame 100"

* 13,220-lb capacity front axle

* 21,000-lb capacity locking rear axle

* Cummins B6.7 (6.7L) 300 HP @ 2,600 rpm, torque 660 lb-ft @ 1,600 rpm

* Allison 3500 RDS wide ratio, 5-speed automatic transmission with double overdrive

* L0006EY White Elite EY

** CHASSIS INFORMATION **

1 Includes the following:

* Carb22

* Front Frame Extensions.

SPECIAL CHARGES

1 Delivery to Customer.

1 First Article Inspection, Digital

** ADDITIONAL INFORMATION **

* Bluejeans.

6 CALIFORNIA TIRE FEE

** ALTERED FROM STANDARD **

1 .

** ALTERED FROM STANDARD **

1 Terex Utilities to License & Register Completed Unit with California DMV:

* Additional Taxes & Fees to be determined at time of invoice.

Qty. Description

OPTIONS:

ADD

1. Federal Excise Tax will be added if certificate is not supplied with order.
2. The following items must be considered by the purchaser if not already included:
Back-up Alarm \$150.00; Strobe Light \$525.00; Wheel Chocks \$110.00;
Outrigger Pads \$200.00 to \$650.00 (based on pad size & type); Truck Grounding Cable \$550.00;
Barricade Kit \$895.00; Hydraulic Over Load Protection (derrick only, price will vary
based on final option selection); Boom / Boom Stow Interlock \$700.00; Engine Stop / Start
\$200.00 to \$795.00 (based on unit model); Auxiliary Let Down \$1500.00; and Platform
Liner \$380.00 to \$625.00 (based on platform size).
3. Terex Utilities, Inc. strongly recommends all installation accessories be located up front in
front in the quote or secondarily on the approved engineering drawing. Any accessories located
or relocated during manufacturing may be subject to additional charges.
4. Terex Utilities, Inc. - Assembly in Watertown, South Dakota is ISO 9001:2000 Certified.

Customer Information:

Customer: **Terex South Dakota**
Customer Number: **22806**

End Customer: **Ind Orig Equip Manufactur**
Contact: **Steven Fedt**

Ref C7287-21
Platform And Pack

Quote Information:

Quote Date: 03/22/2022

Base Quote Information:

<u>Qty</u>	<u>Ins</u>	<u>Item Description</u>	<u>Notes/Specifications</u>
1	N	Forestry Body 11' Notched	
		Overall Length - - - - -11'3"	Long sills (34"spc.) - -7" structural channel
		Overall Width - - - - -95"	Pole Saw and Ladder Box installed Streetside
		Overall Height - - - - -62"	Lights- - - -Clearance, S/T/T, Backup and Strobe
		Interior Height - - - - -52"	Forestry Body prime paint - -Complete immersion in
		Floor Length - - - - -110"	electrodeposition gray epoxy primer.
		Rear Gate Height - - - - -24" (opens to curbside)	Undercoating - - - - -Complete undercoating
		Chip Capacity- - - - -15.05 Cubic Yards	Finish paint - Prime only
		Forestry Body Floor - - -12 Ga. HS smooth steel	WARRANTY: Standard Knapheide Limited Warranty
		Cross sills (18"spc.)- -3" Structural Channel	
1	Y	KFB Special Roof Height	62" interior clear height. 73" overall height.
1	N	Hoist KH-1512SF-AE	
1	Y	KFB Ladder Box Streetside	ilo standard curb side
1	Y	Coal Tar Coating 11'&12'	Interior
1	Y	Reinforce Roof/Rear	Reinforce roof and rear end for boom rest support.
1	N	Forestry Pack KPF-944850	Includes: (1) Full length shelf, 54"L, centered side to side. (3) Combo hooks mounted in curb side compartment. 3pt T-Handle latches with master lock system.
3	Y	KPF Combo Hooks 3-0-3	Six total in curb side front vertical. 3-0-3.
1	Y	KPF Louver Vents-1Pr R2V	
1	Y	KPF 3PT T-Handle Latches	
1	N	Aerial Platform 50"L	94"W x 6"H. Cutout in floor for aerial.
2	N	Grip Strut Access Step Ay	Bolt-on style. Shipped loose. One for each side of the aerial platform.
4	N	Bolt-On Grab Handles	Two per side of aerial platform. Four total. -2 Pool type and 2 for front of Knap Pack. Shipped loose.
1	Y	Forestry Body Ext White	Exterior of body painted Knapheide white. Some touch up may be required by distributor after shipment and handling.
1	Y	Knap Pack Ext White	Exterior of pack painted Knapheide white. Some touch up may be required by distributor after shipment and handling.

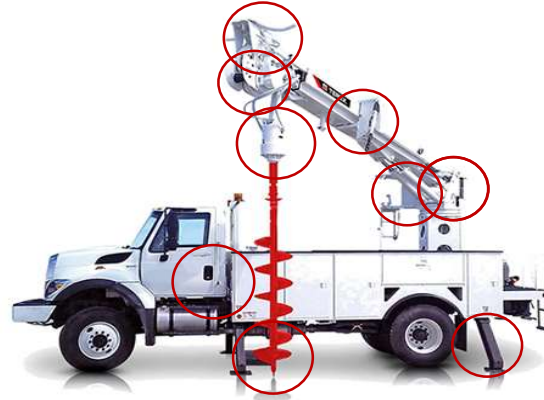

Fleet Maintenance and Inspection Agreements

Contact us NOW for pricing! 1-210-476-7768

- We cater to your needs through pay-as-you-go, customized service agreements.
- We can cover your entire fleet, for all manufacturers!
- Our inspections provide a trusted and certified review of your unit.
- Maintain your Terex Limited Lifetime Structural Warranty eligibility by utilizing Terex Services for your maintenance needs!

Annual Inspection (4 Options)	Basic	Silver	Gold	Platinum
	✓	✓	✓	✓
+ Dielectric Test		✓	✓	✓
+ Lubrication & Filters			✓	✓
+ Rotation Bolt Torque Checks*				✓

180-Day Inspection (3 Options)	Basic	Silver	Gold
	✓	✓	✓
+ Lubrication & Filters		✓	✓
+ Rotation Bolt Torque Checks*			✓

90-Day Inspection (2 Options)	Basic	Silver
	✓	✓
+ Lubrication & Filters*		✓

We come to you!



Or you can come to us!



Get preferential travel rates by including your entire fleet!

•• Be sure to select your preferred inspection level to be quoted.

TEREX SERVICE CENTERS KEEP YOUR EQUIPMENT WORKING



*Terex recommends selecting to comply with ANSI/OSHA requirements.

Preventive Maintenance and Inspection Program

XTPRO56 **XT PRO Series Overcenter Articulating Aerial Device**



5 = number of years of preventive maintenance service in the quote
 1 = quantity of units to include in the quote

Include field service travel time (otherwise units will be serviced at a branch)

Please indicate customer location: West of Colorado Mountains

Include leveling chain replacement at 5 years

NOTE: The selected unit does not require leveling chain inspection nor replacement at 5 years

Preventive Maintenance Packages, Single Unit

Basic	Silver	Gold	Platinum	Custom
- Yearly visual inspection and operational test of all critical components.* <i>* NOTE- Basic package by itself does not qualify as the required annual inspection under the Terex Limited Product Warranty</i>	- Yearly visual inspection and operational test of all critical components. - Annual preventive maintenance as defined in maintenance manual, including the following: - Torque checking of rotation bolts, drift test, lubrication, hydraulic oil test, dielectric test - Replacement hydraulic oil filters and lubricant - Qualifies as the required annual inspection under the Terex Limited Product Warranty	- Yearly visual inspection and operational test of all critical components. - Annual preventive maintenance as defined in maintenance manual, including the following: - Torque checking of rotation bolts, drift test, lubrication, hydraulic oil test, dielectric test - Replacement hydraulic oil filters and lubricant - Qualifies as the required annual inspection under the Terex Limited Product Warranty - 180 day inspection and preventive maintenance - Replacement hydraulic oil filters and lubricant	- Yearly visual inspection and operational test of all critical components. - Annual preventive maintenance as defined in maintenance manual, including the following: - Torque checking of rotation bolts, drift test, lubrication, hydraulic oil test, dielectric test - Replacement hydraulic oil filters and lubricant - Qualifies as the required annual inspection under the Terex Limited Product Warranty - 180 day inspection and preventive maintenance - Replacement hydraulic oil filters and lubricant - 5 years preventive maintenance - Removal and inspection of leveling chains and insulator rods** <i>** Not required for XT PROs, OPTIMAS, units equipped with Extended Life leveling chains, or units not equipped with leveling chains.</i>	Package includes: See custom package configurator
Standard service price: \$5,100 Your package price: \$4,416	Standard service price: \$6,851 Your package price: \$5,932	Standard service price: \$11,951 Your package price: \$10,348	Standard service price: \$11,951 Your package price: \$10,348	Standard service price: \$11,951 Your package price: \$10,348
You save: \$684	You save: \$919	You save: \$1,603	You save: \$1,603	You save: \$1,603

Select your package: Basic (customer declines, among others, torque check of critical fasteners)
 Silver Gold Platinum Custom

Customer confirms selection of the maintenance package indicated for the price and duration specified. Customer accepts and agrees to the attached Terex Terms and Conditions of Sale, which govern this transaction. In the event of early cancellation of this Agreement, Customer agrees that Terex shall be entitled to retain as liquidated damages, and not as a penalty, any fees paid in advance, which the parties agree reasonably approximate Terex's actual damages.

Customer signature: _____

Preventive Maintenance and Inspection Program

Custom Package Configurator

Product Code:

XT PRO Series Overcenter Articulating Aerial Device



= number of years of service

= quantity of units to include in the quote

Include the following periodic Preventive Maintenance:

- 90 Days (360 Hours)
- 180 Days (720 Hours)
- 270 Days (1,080 Hours)
- 12 Months (1,050 Hours)
- Dielectric Test (Yearly)
- 5 Years (5,250 Hours) Include leveling chain replacement at 5 years

NOTE: The selected unit does not require leveling chain inspection nor replacement at 5 years

Include field service travel time

Please indicate customer location:

Custom

Standard service price:
\$11,951
Your package price:
\$10,348

You save: \$1,603

[Visit us at TEREX.com](http://TEREX.com)

PREVENTIVE MAINTENANCE AND INSPECTION PROGRAM

A **SCOPE OF SERVICES**

- 1 For each Terex Utilities equipment unit specified in section C below, Service Provider will provide, annually, for the Basic Package: Visual inspections and operational tests; for the Silver Package: Annual preventive maintenance, dielectric test, lubricant and hydraulic filter; for the Gold Package: 90-Day preventive maintenance (except for XT PRO), 180-Day preventive maintenance, 270-Day preventive maintenance (except for XT PRO), Annual preventive maintenance, dielectric test; for the Platinum Package: 90-Day preventive maintenance (except for XT PRO), 180-Day preventive maintenance, 270-Day preventive maintenance (except for XT PRO), Annual preventive maintenance, dielectric test, 5 years preventive maintenance ; for the Custom Package: 180-Day preventive maintenance, Annual preventive maintenance, dielectric test, lubricant and hydraulic filter, ; services will be provided for 5 years, provided this Agreement has not expired or been terminated. Such Maintenance will be consistent with the applicable service manual for each Equipment unit. The commencement date for such Maintenance for the Equipment will be the on the equipment delivery date. Service Provider will have no obligation to perform Maintenance on any Equipment after termination or expiration of this Agreement.

- 2 The Maintenance will be conducted at the Designated Service Location specified in section C below. Maintenance outside such location will be performed at an additional fee to be agreed by the parties in advance. Customer shall provide a safe work area for the Maintenance, with electric power, water, waste disposal, and access provisions. Vehicle must be provided free and clear of debris to allow technician safe access to the equipment controls and pedestal area. Service Provider will provide periodic reports to Customer of the Maintenance that has been performed.

- 3 Maintenance and Inspection of the Equipment will be scheduled by Customer at least five (5) business days in advance. The parties will cooperate to ensure advance notice is provided to Service Provider of any additional service that may be requested.

- 4 In the event an Equipment unit does not meet the Inspection criteria because of needed repairs (“Repairs”), Service Provider will provide an estimated cost for such Repairs. Repairs will be performed upon Customer’s approval and issuance of a purchase order. The Repairs must be performed prior to Service Provider acknowledging that the Inspection is completed.

- 5 Maintenance, Inspections, and Repairs will be performed by Service Provider on the Equipment within the hours of 7:00 a.m. to 5:00 p.m. on normal business days (excluding weekends and public holidays). In the event Customer schedules Maintenance, Inspections, and/or Repairs outside of such hours, or on weekends or public holidays, the following additional fees will be charged: \$130.00 an hour, or for prorated portions of an hour depending on the time of completion. Fees will be billed from the time the Service Provider reaches the jobsite.

- 6 In the event Customer proposes changes to the Scope of Services stated herein, Service Provider reserves the right to renegotiate the fee agreed between the parties.

B **FEE SCHEDULE**

For the Basic Package: \$4,416; for the Silver Package: \$5,932; for the Gold Package: \$10,348; for the Platinum Package: \$10,348; for the Custom Package: \$10,348; for 5 years of service, with payment by Customer to Service Provider due upon signing of this Agreement.

C **LIST OF EQUIPMENT UNITS TO BE INSPECTED AND MAINTAINED**

The following equipment, listed by Serial Number and Model, is included under this Agreement:

Equipment Model: XTPRO56

Equipment Serial Number(s):

This document will be supplemented with serial numbers for the units once they are available

Designated Service Location:

CUSTOMER'S ADDRESS

("Seller")

TERMS AND CONDITIONS OF SALE

1. Terms and Conditions. The provision by Seller to Buyer of any Equipment or Parts (collectively referred to as "Products") and field labor, reconditioning, repair, maintenance and inspection services (collectively referred to herein as "Services") shall be exclusively governed by these Terms and Conditions of Sale ("Terms and Conditions") and Seller's sales order (collectively referred to as "Agreement"). This Agreement cancels and supersedes any and all terms and conditions previously issued by Seller and shall remain in effect unless and until superseded in writing by Seller. Acceptance of an order for Products or Services by Seller shall be deemed to constitute a binding agreement between the parties pursuant to these Terms and Conditions and Buyer agrees that the order may not thereafter be countermanded or otherwise changed without the explicit prior written consent of Seller. No other terms and conditions shall apply, including the terms of any purchase order submitted to Seller by Buyer, whether or not objected to by Seller or whether or not such terms are inconsistent or conflict with or are in addition to these Terms and Conditions. These Terms and Conditions shall be deemed accepted by Buyer if any of the following occurs: (i) if confirmed by Buyer, (ii) if undisputed by Buyer within ten (10) days after receipt, or (iii) if Seller delivers Products or Services to Buyer. Any communication construed as an offer by Seller and acceptance thereof is expressly limited to these Terms and Conditions. The Products are intended for industrial/commercial use by professional contractors and their trained employees and are not intended for use by consumers.

2. Terms of Payments. Payment for Products or Services purchased by Buyer shall be made in accordance with any of the following terms, provided they have been previously arranged with and expressly approved by Seller in writing: (1) cash in advance; (2) confirmed, irrevocable letter of credit established in such amount and form and at such time and at such bank as shall be approved by Seller in respect of each order; (3) credit account purchases for which payment will be due and payable on net thirty (30) day terms, plus service and other charges applicable to past due amounts in accordance with Seller's written notices; or (4) other payment arrangements expressly approved by Seller in writing prior to or at the time the order is placed. If any Buyer credit account purchase is not paid in accordance with Seller's credit payment terms, in addition to any other remedies allowed in equity or by law, Seller may refuse to make further shipments without advance payment by Buyer. Nothing contained herein shall be construed as requiring Seller to sell any Products or Services to Buyer on credit terms at any time, or prohibiting Seller from making any and all credit decisions which it, in its sole discretion, deems appropriate for Seller. Seller may charge interest on all amounts not paid when due and Buyer agrees to pay such interest calculated on a daily basis, from the date that payment was due until the Seller receives payment in full, at the rate of 1.5% per month or the maximum rate permitted by applicable law. Seller shall be entitled to an equitable adjustment in the price of Products or Services in order to account for increases in the cost to Seller of labor or materials, or in the event of unanticipated or unforeseen circumstances.

3. Taxes and Duties. Unless otherwise specified, prices quoted do not include taxes or duties of any kind or nature. Buyer agrees that it will be responsible for filing all tax returns and paying applicable tax, duty, export preparation charge and export documentation charge resulting from the purchase of any Products or Services. In addition, in the event any other similar tax is determined to apply to Buyer's purchase of any Products or Services from Seller, Buyer agrees to indemnify and hold Seller harmless from and against any and all such other similar taxes, duties and fees. All prices quoted are U.S. DOLLARS unless otherwise specified. The amount of any present or future taxes applicable to the sale, transfer, lease or use of any Products shall be paid by Buyer; or in lieu thereof, Buyer shall provide Seller with a tax exemption certificate satisfactory to the applicable taxing authority proving that no such tax is due and payable upon such sale, transfer, lease or use.

4. Title, Risk, Transportation and Delivery. Unless otherwise stated in writing, all prices and delivery are FCA, Seller's Premises (Incoterms 2010). Title and all risk of loss or damage to Products shall pass to Buyer upon delivery, as per Incoterms 2010. Any claims for loss, damage or delay in transit must be entered and prosecuted by the Buyer directly with the carrier, who is hereby declared to be the agent of the Buyer. In the event delay in shipment of Products is caused by Buyer's failure to furnish necessary information with respect to data and details for Buyer's specifications, Seller, may, in its sole discretion, extend the date of shipment for a reasonable time. In the event delay in shipment is caused by Buyer or at Buyer's request, and there are Products that are not shipped within ten (10) days from the first date they are ready to be shipped, Seller may, in its sole discretion, sell such Products to another buyer without any liability or responsibility to Buyer whatsoever. All payments shall be made in accordance with the terms of the applicable invoice. In addition, storage charges due to delay in furnishing delivery instructions, arranging and establishing a method of payment satisfactory to Seller, or submitting valid import permits or licenses, or any other delay caused by Buyer or at Buyer's request, will be for the account of Buyer. **SELLER SHALL NOT BE LIABLE FOR ANY LOSS OF USE OR FOR ANY OTHER INDIRECT, CONSEQUENTIAL, INCIDENTAL OR OTHER DAMAGES OR LOSSES DUE TO DELAY IN SCHEDULED DELIVERY.** Claims for shortages in shipments shall be deemed waived and released by Buyer unless made in writing within five (5) days after Buyer's receipt of shipment. Seller's responsibility for shipment shall cease upon delivery of the Products to the place of shipment, and all claims occurring thereafter shall be made to or against the carrier by Buyer.

5. Cancellation. Prior to delivery to place of shipment, a Products order may be cancelled only with Seller's prior written consent and upon terms indemnifying Seller from all resulting losses and damages. Seller shall have the right to cancel and refuse to complete a Products or Services order if any term and/or condition governing this agreement is not complied with by Buyer. In the event of cancellation by Seller, or in the event Seller consents to a request by Buyer to stop work or to cancel the whole or any part of any order, Buyer shall make reimbursement to Seller, as follows: (i) any and all work that can be completed within (30) days from date of notification to stop work on account of cancellation shall be completed, shipped and paid in full; and (ii) for work in progress and any materials and supplies procured or for which definite commitments have been made by Seller in connection with the order, Buyer shall pay such sums as may be required to fully compensate Seller for actual costs incurred, plus fifteen percent (15%). Buyer may not cancel any order after Seller's delivery to place of shipment. Orders for "Special" Equipment may not be cancelled after acceptance, except by Seller. Items of "Special" Equipment are those that differ from standard Seller specifications, have a limited market, or incorporate specifications that have been determined for a specific application. Determination of whether an item of Equipment is "Special" shall be made by Seller in its sole discretion.

6. Inspection and Acceptance. Buyer agrees that it shall inspect the Products or Services immediately after receipt of Products or completion of Services and promptly notify Seller in writing of any non-conformity or defect within 10 days after the Products are put into service or the Services are completed, but not more than thirty (30) days after delivery or completion. Buyer further agrees that confirmation that the Products or Services comply with the order, its commercial use of the Products or its failure to give prompt notice of non-conformity or defect shall constitute acceptance. Acceptance shall be final and Buyer waives the right to revoke acceptance for any reason, whether or not known by Buyer at the time of such acceptance. Acceptance shall automatically cause the provisions of Seller's warranty to apply and govern the rights, obligations and liabilities of the parties with respect to such nonconformity or defect, provided under no circumstances shall rejection give rise to any liability of Seller for incidental or consequential damages or losses of any kind.

7. Warranty for Products and Services.

(a) For Equipment:

Seller warrants its new Equipment manufactured and sold worldwide to be free, under normal use and service, from defects in material or workmanship for the time period designated in the warranty applicable to the particular type, make and model of Equipment or, in the event no specific warranty exists for such Equipment, for a period of twelve (12) months from the date of delivery.

(b) For Parts:

- (i) Seller warrants that Parts supplied by Seller will be free, under normal use and service, from defects in material or workmanship for a period of twelve (12) months from the date of delivery, where Seller is the OEM of such Parts;
- (ii) Seller warrants that that Parts supplied in connection with a warranty repair on Equipment sold by Seller will be free, under normal use and service, from defects in material or workmanship for a period of time equal to the OEM warranty provided by the manufacturer of such Parts, but if there is no OEM warranty on such Parts, then such warranty period shall terminate upon the expiration of the warranty for the Equipment originally sold by Seller; and
- (iii) Seller warrants that Parts supplied in connection with Services performed by Seller on equipment not originally sold by Seller will be free, under normal use and service, from defects in material or workmanship for a period of time equal to the OEM warranty provided by the manufacturer of such Parts.

(c) For Services:

- (i) Seller warrants that its field and shop labor services will be free from defects in workmanship for a period of ninety (90) days from the date of completion of such services;
- (ii) Seller warrants that its labor supplied in connection with its reconditioning services on mobile equipment will be free from defects in workmanship for a period of six (6) months from the date of completion of such services; and
- (iii) Seller provides no warranty, express or implied, on its inspection services.

The foregoing warranties shall only be valid if Buyer sends Seller written notice of the defect within thirty (30) days of its discovery and establishes that: (i) the Equipment or Parts, or any equipment subject to any Service, has been maintained and operated within the limits of rated and normal usage; and (ii) the defect did not result in any manner from the intentional or negligent action or inaction by Buyer, its agents or employees. If requested by Seller, Buyer must return the defective Equipment or Parts to Seller's facility for inspection, and if Buyer cannot establish that conditions (i) and (ii) above have been met, then the foregoing warranties shall not cover the alleged defect. Failure to give written notice of defect within such period shall be a waiver of the foregoing warranties and any assistance rendered thereafter shall not extend or revive it. Equipment, accessories, assemblies, components and Parts which are not manufactured by Seller are subject to the warranty of their respective manufacturers. The foregoing warranties shall be void in the event Buyer has carried out modifications or reconditioning work on the Equipment or Parts without the prior written consent of Seller. The foregoing warranties shall not cover any item on which serial numbers have been altered, defaced or removed. Maintenance and wear parts are not covered by the foregoing warranties and are the sole maintenance responsibility of Buyer. The foregoing warranties are limited to the first retail purchaser and are not assignable or otherwise transferable without the written agreement of Seller. **THE FOREGOING WARRANTIES ARE EXPRESSLY IN LIEU OF AND EXCLUDE ALL OTHER WARRANTIES, EXPRESS OR IMPLIED (INCLUDING THE WARRANTIES OF MERCHANTABILITY AND FITNESS FOR A PARTICULAR PURPOSE) AND ALL OTHER OBLIGATIONS OR LIABILITY ON SELLER'S PART. THERE ARE NO WARRANTIES THAT EXTEND BEYOND THE LIMITED WARRANTIES CONTAINED HEREIN.** Seller neither assumes nor authorizes any other person to assume for Seller any other liability in connection with the sale of Seller's Equipment, Parts or Services. The foregoing warranties shall not apply to any Equipment or Parts or any part thereof purchased from Seller, or any equipment which was the subject of any Service performed by Seller, which has been subject to misuse, alteration, abuse, negligence, accident, acts of God or sabotage. No action by either party shall operate to extend or revive the foregoing limited warranties without the prior written consent of Seller.

8. Remedies for Breach. IN THE EVENT OF ANY BREACH OF WARRANTY BY SELLER, THE PARTIES AGREE THAT SELLER'S LIABILITY SHALL BE LIMITED EXCLUSIVELY TO THE REMEDIES OF REPAIR OR REPLACEMENT (AT SELLER'S SOLE DISCRETION) OF ANY DEFECTIVE PRODUCT OR THE RE-PERFORMANCE OF ANY DEFECTIVE SERVICES COVERED BY THE WARRANTY. In no event shall any repair or replacement of any defective Equipment or Parts, or the re-performance of any defective Services covered by the Seller's warranties in Section 7 extend the length of such warranties beyond the applicable periods specified in Section 7 above.

9. Limitation of Liability. NOTWITHSTANDING ANYTHING CONTAINED IN THIS AGREEMENT TO THE CONTRARY, SELLER AND ITS AFFILIATES SHALL NOT BE LIABLE FOR, AND SPECIFICALLY DISCLAIM, ANY LIABILITY FOR ANY: (A) LOST PROFITS AND/OR BUSINESS INTERRUPTION (WHETHER DIRECT OR INDIRECT); AND (B) INCIDENTAL, INDIRECT, CONSEQUENTIAL (WHETHER DIRECT OR INDIRECT) OR OTHER DAMAGES OR LOSSES OF ANY KIND, including without limitation, labor costs, loss of use, equipment rental, third party repairs, investigation costs, personal injury, emotional or mental distress, penalties, loss of service of personnel, or failure of Products to comply with any applicable laws; whether or not arising from breach of contract, warranty, negligence, product liability or otherwise. Notwithstanding anything contained herein to the contrary, in no event shall Seller's liability exceed the total order value.

10. Limitation of Actions. Any action for breach of this agreement must be commenced within one (1) year after the cause of action has accrued.

11. Specification Changes. In the event Seller incurs additional expense because of changes in specifications or drawings previously approved by Buyer, or in the event Seller is required to modify the ordered Products, perform any additional Services, perform any additional work or supply any additional Products, the additional expense shall be added to the purchase price. Seller shall have the right, in its sole discretion, to accept or reject any changes in specifications requested by Buyer. In no event shall any changes in specifications be made or accepted thirty (30) days prior to launch date or thereafter.

12. Security Interest. Buyer grants Seller a security interest in the Products purchased and the proceeds thereof. The security interest shall continue until payment in full of the purchase price and payment and performance by Buyer of all of its other obligations hereunder. Seller is entitled to all remedies of a secured party after default under the Ohio Uniform Commercial Code or other applicable law, including but not limited to the applicable Personal Property Security Act in Canada, in addition to all other rights provided by contract and by operation of law. Buyer agrees to pay to Seller, in addition to the interest on overdue sums due, reasonable attorney fees, court costs and other expenses of Seller incurred in enforcing Seller's rights. The Products purchased shall remain personal property and shall not become or be deemed a fixture or a part of any real estate on which it may be located. Buyer agrees to execute any instrument or document considered necessary by Seller to perfect its security interest in the Products including, but not limited to, financing statements, chattel mortgages, deeds of trust, deeds to secure debt, mortgages or other security instruments.

13. Insurance. Until the purchase price of any Product is paid in full or the Service is completed, the Buyer shall provide and maintain insurance equal to the total value of any such Product delivered hereunder against customary casualties and risks; including, but not limited to fire and explosion, and shall also insure against liability for accidents and injuries to the public or to employees, by adding Seller as additional insured with waiver of subrogation, and in an amount satisfactory to Seller. If the Buyer fails to provide such insurance, it then becomes the Buyer's responsibility to notify the Seller so that the Seller may provide same; and the cost thereof shall be added to the contract price. All loss resulting from the failure to affect such insurance shall be assumed by the Buyer.

14. Return of Products. Products may be returned only with Seller's prior written consent and upon the following conditions: (i) such Products must be new, unused and undamaged (and not obsolete), in good working order and in first class marketable condition; (ii) such Products must have been originally purchased by Buyer from Seller within the previous twelve (12) month period; and (iii) such Products shall be returned in the same condition as that in which they were sold by Seller to Buyer, and in the original packaging. Notwithstanding the foregoing, wire rope, cut chain, electrical components, special orders of Products or any Products which are altered or manufactured pursuant to Buyer's requirements and specifications are not returnable. The price for the repurchase of such Products shall be the invoice price previously received by Seller from Buyer for the Products in question, net of freight and taxes, and less a restocking fee to be determined by Seller at the time of the return.

15. Patents, Copyrights, Trademarks, Confidentiality. No license or other rights under any patents, copyrights or trademarks owned or controlled by Seller or under which Seller is licensed are granted to Buyer or implied by the sale of Products or the provision of Services. Buyer shall not identify as genuine products of Seller Products purchased hereunder which Buyer has treated, modified or altered in any way, nor shall Buyer use Seller's trademarks to identify such products; provided, however, that Buyer may identify such products as utilizing, containing or having been manufactured from genuine products of Seller as treated, modified or altered by Buyer or Buyer's representative, upon written prior approval of Seller. All plans, photographs, designs, drawings, blueprints, manuals, specifications and other documents relating to the business of Seller ("Information") shall be and remain the exclusive property of Seller and shall be treated by Buyer as confidential information and not disclosed, given, loaned, exhibited, sold or transferred to any third party without Seller's prior written approval; provided, however, that these restrictions shall not apply to Information that Buyer can demonstrate: (a) at the time of disclosure, is generally known to the public other than as a result of a breach of this agreement by Buyer; or (b) is already in Buyer's possession at the time of disclosure by from a third party having a right to impart such Information.

16. Default and Seller's Remedies. In the event of default by Buyer, all unpaid sums and installments owed to Seller, shall, at the Seller's sole option, become immediately due and payable without notice of any kind to Buyer. In addition to its right of acceleration, Seller may pursue any and all remedies allowed by law or in equity, including but not limited to any and all remedies available to it under the Ohio Uniform Commercial Code. In addition to the foregoing, and not in limitation thereof, Seller shall have the right to set off any credits or amounts owed to Buyer against any amounts owed by Buyer to Seller.

17. Indemnification by Buyer. Buyer hereby agrees to indemnify, release, defend and hold harmless Seller, its directors, officers, employees, agents, representatives, successors, and assigns against any and all suits, actions or proceedings at law or in equity (including the costs, expenses and reasonable attorney's fees incurred in connection with the defense of any such matter) and from any and all claims demands, losses, judgments, damages, costs, expenses or liabilities, to any person whatsoever (including Buyer's and Seller's employees or any third party), or damage to any property (including Buyer's property) arising out of or in any way connected with any act, omission, negligence or willful misconduct of Buyer, its directors, officers, employees, agents, representatives, successors or assigns with respect to its purchase, use, operation, maintenance or installation of any Services or any Parts or Equipment furnished hereunder, or any breach by Buyer of these Terms and Conditions of Sale. If Buyer fails to fulfill any of its obligations under this paragraph or this agreement, Buyer agrees to pay Seller all costs, expenses and attorney's fees incurred by Seller to establish or enforce Seller's rights under this paragraph or this agreement. The provisions of this paragraph are in addition to any other rights or obligations set forth in this agreement.

18. Installation. Unless otherwise expressly agreed in writing, Buyer shall be solely responsible for the installation and erection of the Products purchased. Although Seller may in some cases provide a serviceman, data and drawings to aid Buyer with installation or start-up, Seller assumes no responsibility for proper installation or support of any Product when installed and disclaims any express or implied warranties with respect to such installation and support. Notwithstanding whether data and drawings are provided or a serviceman aids in the installation, Buyer shall indemnify and hold Seller harmless and at Seller's request, defend Seller from all claims, demands or legal proceedings (including the costs, expenses and reasonable attorney's fees incurred in connection with the defense of any such matter) which may be made or brought against Seller in connection with damage or personal injury arising out of said installation or start-up.

19. On-Site Services. In the event that Seller is providing Services at Buyer's worksite (or at a location designated by Buyer), Buyer shall provide Seller free and clear access and an adequate power supply in order to perform the Services. Buyer shall maintain safe working conditions at the worksite, including, without limitation, implementing appropriate procedures regarding hazardous materials and energization and de-energization of power systems. Buyer shall immediately remedy any unsafe working condition at the worksite. Seller shall be entitled to suspend or terminate the Services in the event it determines that the worksite is unsafe. Seller shall have no responsibility or liability for any pre-existing condition of the worksite including, without limitation, violations of safety rules, building codes, zoning ordinances or other laws or regulations ("Regulations"). In the event that any unsafe working condition or failure of the worksite to comply with a Regulation results in an increase in the Seller's cost of, or the time required for, performance of the Services, Seller may make an equitable adjustment in price and schedule. Buyer authorizes Seller to perform the disassembly and inspection of any equipment necessary to provide the Services, including provision of all necessary Parts and labor, and agrees that Seller is not responsible for any damage or loss due to causes beyond Seller's control. Unless expressly agreed in writing, Services do not include architectural/engineering services or structural changes to Buyer's premises.

20. Additional Terms of Equipment Services. In the event Seller performs Services on Equipment for Buyer, Buyer hereby authorizes Seller to inspect and disassemble the Equipment provided, and authorizes Seller to perform the Services indicated in the applicable estimate, quote or work order (including provision of all necessary parts and labor). Buyer agrees that Seller is not responsible for: (i) damage or loss to the Equipment, or loss of personal property, caused by fire, theft, or causes beyond Seller's control, or (ii) delays in completion of Services caused by unavailability of parts or other causes. Buyer authorizes Seller and its employees to operate the Equipment on streets, highways or elsewhere for the purpose of testing and/or inspection. Buyer will be subject to a storage fee of \$20 per day for any Equipment left on Seller's premises more than fifteen (15) days after completion of the Services. Buyer grants Seller a security interest and lien in the Equipment and any parts supplied until payment in full of any amounts owed by Buyer to Seller. Seller is entitled to all remedies of a secured party after default under the Uniform Commercial Code in addition to all other rights provided under law or equity. Buyer agrees to pay to Seller, in addition to interest at the rate of 18% annually on overdue sums (or the maximum rate permitted by law), reasonable attorney fees, court costs and other expenses incurred by Seller in enforcing Seller's rights. Buyer agrees to execute any instrument or document considered necessary by Seller to perfect its security interest in the Equipment. In the event Buyer fails to retrieve the Equipment within ninety (90) days after completion of the Services, Buyer grants Seller a power of attorney to sell, or otherwise dispose of, such Equipment and to convey title to a purchaser of such Equipment, and to apply any sale proceeds against any amount owed by Buyer to Seller. In the event of default by Buyer, all unpaid sums owed to Seller shall, at Seller's sole option, become immediately due and payable without notice of any kind to Buyer.

21. Force Majeure. The Seller shall not be liable to the Buyer or be deemed to be in breach of this agreement by reason of any delay in performing, or any failure to perform, any of the Seller's obligations in relation to the Products or Services if the delay or failure was due to any cause beyond the reasonable control of the Seller including (without limitation) strike, lockout, riot, civil commotion, fire, accident, explosion, tempest, act of God, war, epidemic, stoppage of transport, terrorist activity, supply shortage or changes in government, governmental agency, laws, regulations or administrative practices.

22. Anti-Corruption; Export Controls; No Boycotts. Buyer agrees that it shall, and that any party retained or paid by the Buyer ("Retained Party") shall, comply with all applicable laws including, but not limited to, laws prohibiting public corruption and commercial bribery. Buyer further agrees that it shall, and that any Retained Party shall, comply with all applicable export controls, economic sanctions, embargoes and regulations regarding the export, re-export, shipment, distribution and/or sale of Products, technology, information or warranty related services. Buyer further agrees that it shall not, and any Retained Party shall not, export or re-export Products, technology, information or warranty related services directly or with its knowledge indirectly into Iran, Cuba, Syria, North Korea, the Crimea Region of the Ukraine or Russia without Buyer first obtaining written approval from Seller. Failure to comply strictly with this section and all applicable laws, regulations and licensing/approval requirements shall be grounds for immediate termination of this agreement by Seller. Notwithstanding anything to the contrary contained in any agreement between the Buyer and Seller or in any other document or agreement relating to the Products sold hereunder, Seller will not comply with requests related to the boycott of any country or other jurisdiction, except to the extent such boycott is required by or otherwise not inconsistent with United States law.

23. Telematics. If a telematics system is included with the Equipment, the telematics system is administered by a third party (“Teleservice Provider”) and collects a range of operational data about the Equipment including, but not limited to, usage, performance and reliability. Buyer consents to Seller’s obtaining such data from the Teleservice Provider for warranty, product improvement, marketing and customer support purposes. In addition to the foregoing, Buyer consents to Seller’s collection, management and reporting of data (personal and non-personal) about the Equipment including, but not limited to, fuel consumption, up/down times, operation, defects, parts replacement, movement and location. Buyer shall gain any prior explicit consent from its customers and/or any third party, as required by applicable laws, enabling Seller and/or third parties to provide teleservices and data to Buyer. Buyer shall comply with all applicable laws relating to the provision of teleservices, including without limitations any applicable data protection laws.

24. Construction and Severability. This agreement constitutes the entire agreement between the parties regarding the subject matter hereto and shall be construed and enforced in accordance with the laws of the State of Ohio. Seller shall not be bound by any agent's, employees or any other representation, promise or inducement not set forth herein. The invalidity or unenforceability of any provisions of this agreement shall not affect any other provision and this agreement shall be construed in all respects as if such invalid or unenforceable provision were omitted.

25. Jurisdiction. The parties agree that the proper and exclusive forum and venue in all legal actions brought to enforce or construe any of the provisions of this sales order agreement shall be in the United States District Court, Northern District of Ohio or, if federal jurisdiction is lacking in such legal action, in the state courts in Cleveland, Ohio.

26. No Assignment. No rights arising under this agreement may be assigned by the Buyer unless expressly agreed to in writing by the Seller.

27. Miscellaneous. Buyer represents that: (i) it is solvent and has the financial ability to pay for the Products or Services; and (ii) it has all requisite right, power and authority to perform its obligations under this agreement.

Prepared for:
 Sheldon Seward
 TEREX UTILITIES BB
 500 OAKWOOD RD
 WATERTOWN, SD 57201
 Phone: 605-882-5515

Prepared by:
 Zachary Burt
 FOUR STAR FREIGHTLINER OF
 MONTGOMERY
 3140 HAYNEVILLE ROAD
 MONTGOMERY, AL 36108
 Phone: 334-263-1085

DIMENSIONS

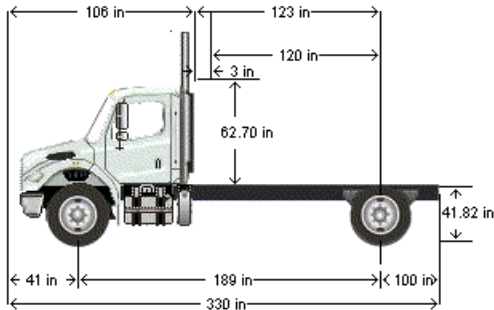

VEHICLE SPECIFICATIONS SUMMARY - DIMENSIONS

Model	M2106
Wheelbase (545)	4800MM (189 INCH) WHEELBASE
Rear Frame Overhang (552)	2550MM (100 INCH) REAR FRAME OVERHANG
Fifth Wheel (578)	NO FIFTH WHEEL
Mounting Location (577)	NO FIFTH WHEEL LOCATION
Maximum Forward Position (in)	0
Maximum Rearward Position (in)	0
Amount of Slide Travel (in)	0
Slide Increment (in)	0
Desired Slide Position (in)	0.0
Cab Size (829)	106 INCH BBC FLAT ROOF ALUMINUM CONVENTIONAL CAB
Sleeper (682)	NO SLEEPER BOX/SLEEPER CAB
Exhaust System (016)	RH OUTBOARD UNDER STEP MOUNTED HORIZONTAL AFTERTREATMENT SYSTEM ASSEMBLY WITH RH B-PILLAR MOUNTED VERTICAL TAILPIPE

TABLE SUMMARY - DIMENSIONS

Prepared for:
 Sheldon Seward
 TEREX UTILITIES BB
 500 OAKWOOD RD
 WATERTOWN, SD 57201
 Phone: 605-882-5515

Prepared by:
 Zachary Burt
 FOUR STAR FREIGHTLINER OF
 MONTGOMERY
 3140 HAYNEVILLE ROAD
 MONTGOMERY, AL 36108
 Phone: 334-263-1085

Dimensions	Inches
Bumper to Back of Cab (BBC)	106.3
Bumper to Centerline of Front Axle (BA)	40.7
Front Axle to Back of Cab (AC)	65.6
Min. Cab to Body Clearance (CB)	3.0
Back of Cab to Centerline of Rear Axle(s) (CA)	123.4
Effective Back of Cab to Centerline of Rear Axle(s) (Effective CA)	120.4
Back of Cab Protrusions (Exhaust/Intake) (CP)	2.0
Back of Cab Protrusions (Side Extenders/Trim Tab) (CP)	0.0
Back of Cab Protrusions (CNG Tank)	0.0
Back of Cab Clearance (CL)	3.0
Back of Cab to End of Frame	223.8
Cab Height (CH)	62.7
Wheelbase (WB)	189.0
Frame Overhang (OH)	100.4
Overall Frame Length	318.8
Overall Length (OAL)	330.1
Rear Axle Spacing	0.0
Unladen Frame Height at Centerline of Rear Axle	41.8

Performance calculations are estimates only. If performance calculations are critical, please contact Customer Application Engineering.

Prepared for:
 Sheldon Seward
 TEREX UTILITIES BB
 500 OAKWOOD RD
 WATERTOWN, SD 57201
 Phone: 605-882-5515

Prepared by:
 Zachary Burt
 FOUR STAR FREIGHTLINER OF
 MONTGOMERY
 3140 HAYNEVILLE ROAD
 MONTGOMERY, AL 36108
 Phone: 334-263-1085

S P E C I F I C A T I O N P R O P O S A L

Data Code	Description	Weight Front	Weight Rear
Price Level			
PRL-23M	M2 PRL-23M (EFF:01/21/20)		
Data Version			
DRL-039	SPECPRO21 DATA RELEASE VER 039		
Vehicle Configuration			
001-172	M2 106 CONVENTIONAL CHASSIS	5,709	3,503
004-223	2024 MODEL YEAR SPECIFIED		
002-004	SET BACK AXLE - TRUCK		
019-001	TRAILER TOWING PROVISION AT END OF FRAME FOR TRUCK	10	10
003-001	LH PRIMARY STEERING LOCATION		
General Service			
AA1-003	TRUCK/TRAILER CONFIGURATION		
AA6-002	DOMICILED, USA (EXCLUDING CALIFORNIA AND CARB OPT-IN STATES)		
A85-010	UTILITY/REPAIR/MAINTENANCE SERVICE		
A84-1UT	UTILITY BUSINESS SEGMENT		
AA4-011	FIXED LOAD COMMODITY		
AA5-006	TERRAIN/DUTY: 10% (SOME) OF THE TIME, IN TRANSIT, IS SPENT ON NON-PAVED ROADS		
AB1-008	MAXIMUM 8% EXPECTED GRADE		
AB5-003	MAINTAINED GRAVEL OR CRUSHED ROCK - MOST SEVERE IN-TRANSIT (BETWEEN SITES) ROAD SURFACE		
995-091	MEDIUM TRUCK WARRANTY		
A66-99D	EXPECTED FRONT AXLE(S) LOAD : 13220.0 lbs		
A68-99D	EXPECTED REAR DRIVE AXLE(S) LOAD : 21000.0 lbs		
A63-99D	EXPECTED GROSS VEHICLE WEIGHT CAPACITY : 33000.0 lbs (Derated)		

Prepared for:
 Sheldon Seward
 TEREX UTILITIES BB
 500 OAKWOOD RD
 WATERTOWN, SD 57201
 Phone: 605-882-5515

Prepared by:
 Zachary Burt
 FOUR STAR FREIGHTLINER OF
 MONTGOMERY
 3140 HAYNEVILLE ROAD
 MONTGOMERY, AL 36108
 Phone: 334-263-1085

Data Code	Description	Weight Front	Weight Rear
A70-99D	EXPECTED GROSS COMBINATION WEIGHT : 45000.0 lbs		
Truck Service			
AA3-006	UTILITY BODY		
AF3-2A5	TEREX		
AF7-99D	EXPECTED BODY/PAYLOAD CG HEIGHT ABOVE FRAME "XX" INCHES : 32.0 in		
Engine			
101-21X	CUM B6.7 300 HP @ 2600 RPM, 2600 GOV, 660 LB-FT @ 1600 RPM		
Electronic Parameters			
79A-075	75 MPH ROAD SPEED LIMIT		
79B-000	CRUISE CONTROL SPEED LIMIT SAME AS ROAD SPEED LIMIT		
79K-005	PTO MODE ENGINE RPM LIMIT - 900 RPM		
79M-001	PTO MODE BRAKE OVERRIDE - SERVICE BRAKE APPLIED		
79P-002	PTO RPM WITH CRUISE SET SWITCH - 700 RPM		
79Q-002	PTO RPM WITH CRUISE RESUME SWITCH - 700 RPM		
79S-001	PTO MODE CANCEL VEHICLE SPEED - 5 MPH		
79U-007	PTO GOVERNOR RAMP RATE - 250 RPM PER SECOND		
79W-001	ONE REMOTE PTO SPEED		
79X-001	PTO SPEED 1 SETTING - 700 RPM		
80G-002	PTO MINIMUM RPM - 700		
80J-001	REGEN INHIBIT SPEED THRESHOLD - 0 MPH		
Engine Equipment			
99C-021	2010 EPA/CARB/GHG21 CONFIGURATION		
99D-010	NO 2008 CARB EMISSION CERTIFICATION		
13E-001	STANDARD OIL PAN		
105-001	ENGINE MOUNTED OIL CHECK AND FILL		
014-099	SIDE OF HOOD AIR INTAKE WITH FIREWALL MOUNTED DONALDSON AIR CLEANER		
124-1D7	DR 12V 160 AMP 28-SI QUADRAMOUNT PAD ALTERNATOR WITH REMOTE BATTERY VOLT SENSE		
292-205	(2) DTNA GENUINE, FLOODED STARTING, MIN 1900CCA, 350RC, THREADED STUD BATTERIES		
290-017	BATTERY BOX FRAME MOUNTED		

Prepared for:
 Sheldon Seward
 TEREX UTILITIES BB
 500 OAKWOOD RD
 WATERTOWN, SD 57201
 Phone: 605-882-5515

Prepared by:
 Zachary Burt
 FOUR STAR FREIGHTLINER OF
 MONTGOMERY
 3140 HAYNEVILLE ROAD
 MONTGOMERY, AL 36108
 Phone: 334-263-1085

Data Code	Description	Weight Front	Weight Rear
* 281-008	STANDARD BATTERY JUMPERS W / Additional ground stud mounted 12 inches aft of the spring shackle		
282-001	SINGLE BATTERY BOX FRAME MOUNTED LH SIDE UNDER CAB		
291-017	WIRE GROUND RETURN FOR BATTERY CABLES WITH ADDITIONAL FRAME GROUND RETURN		
289-001	NON-POLISHED BATTERY BOX COVER		
87P-001	CAB AUXILIARY POWER CABLE	5	
295-029	POSITIVE AND NEGATIVE POSTS FOR JUMPSTART LOCATED ON FRAME NEXT TO STARTER	2	
107-032	CUMMINS TURBOCHARGED 18.7 CFM AIR COMPRESSOR WITH INTERNAL SAFETY VALVE		
108-002	STANDARD MECHANICAL AIR COMPRESSOR GOVERNOR		
131-013	AIR COMPRESSOR DISCHARGE LINE		
152-041	ELECTRONIC ENGINE INTEGRAL SHUTDOWN PROTECTION SYSTEM		
128-076	CUMMINS ENGINE INTEGRAL BRAKE WITH VARIABLE GEOMETRY TURBO ON/OFF	20	
016-1C2	RH OUTBOARD UNDER STEP MOUNTED HORIZONTAL AFTERTREATMENT SYSTEM ASSEMBLY WITH RH B-PILLAR MOUNTED VERTICAL TAILPIPE	30	25
28F-007	ENGINE AFTERTREATMENT DEVICE, AUTOMATIC OVER THE ROAD ACTIVE REGENERATION AND DASH MOUNTED SINGLE REGENERATION REQUEST/INHIBIT SWITCH		
239-026	10 FOOT 06 INCH (126 INCH+0/-5.9 INCH) EXHAUST SYSTEM HEIGHT		
237-1CR	RH CURVED VERTICAL TAILPIPE B-PILLAR MOUNTED ROUTED FROM STEP		
23U-001	6 GALLON DIESEL EXHAUST FLUID TANK		
30N-003	100 PERCENT DIESEL EXHAUST FLUID FILL		
43X-002	LH MEDIUM DUTY STANDARD DIESEL EXHAUST FLUID TANK LOCATION		
23Y-001	STANDARD DIESEL EXHAUST FLUID PUMP MOUNTING		
43Y-001	STANDARD DIESEL EXHAUST FLUID TANK CAP		
242-011	ALUMINUM AFTERTREATMENT DEVICE/MUFFLER/TAILOPIPE SHIELD(S)		
273-058	AIR POWERED ON/OFF ENGINE FAN CLUTCH		

Prepared for:
 Sheldon Seward
 TEREX UTILITIES BB
 500 OAKWOOD RD
 WATERTOWN, SD 57201
 Phone: 605-882-5515

Prepared by:
 Zachary Burt
 FOUR STAR FREIGHTLINER OF
 MONTGOMERY
 3140 HAYNEVILLE ROAD
 MONTGOMERY, AL 36108
 Phone: 334-263-1085

Data Code	Description	Weight Front	Weight Rear
276-001	AUTOMATIC FAN CONTROL WITHOUT DASH SWITCH, NON ENGINE MOUNTED		
110-003	CUMMINS SPIN ON FUEL FILTER		
118-001	FULL FLOW OIL FILTER		
* 266-078	950 SQUARE INCH ALUMINUM RADIATOR	50	
103-039	ANTIFREEZE TO -34F, OAT (NITRITE AND SILICATE FREE) EXTENDED LIFE COOLANT		
171-007	GATES BLUE STRIPE COOLANT HOSES OR EQUIVALENT		
172-001	CONSTANT TENSION HOSE CLAMPS FOR COOLANT HOSES		
270-016	RADIATOR DRAIN VALVE		
168-002	LOWER RADIATOR GUARD		
138-010	PHILLIPS-TEMRO 750 WATT/115 VOLT BLOCK HEATER	4	
140-053	BLACK PLASTIC ENGINE HEATER RECEPTACLE MOUNTED UNDER LH DOOR		
134-001	ALUMINUM FLYWHEEL HOUSING		
132-004	ELECTRIC GRID AIR INTAKE WARMER		
155-058	DELCO 12V 38MT HD STARTER WITH INTEGRATED MAGNETIC SWITCH		

Transmission

342-584	ALLISON 3500 RDS AUTOMATIC TRANSMISSION WITH PTO PROVISION	200	60
---------	--	-----	----

Transmission Equipment

343-339	ALLISON VOCATIONAL PACKAGE 223 - AVAILABLE ON 3000/4000 PRODUCT FAMILIES WITH VOCATIONAL MODELS RDS, HS, MH AND TRV		
84B-012	ALLISON VOCATIONAL RATING FOR ON/OFF HIGHWAY APPLICATIONS AVAILABLE WITH ALL PRODUCT FAMILIES		
84C-022	PRIMARY MODE GEARS, LOWEST GEAR 1, START GEAR 1, HIGHEST GEAR 5, AVAILABLE FOR 3000/4000 PRODUCT FAMILIES ONLY		
84D-022	SECONDARY MODE GEARS, LOWEST GEAR 1, START GEAR 1, HIGHEST GEAR 5, AVAILABLE FOR 3000/4000 PRODUCT FAMILIES ONLY		
84E-017	S5 PERFORMANCE LIMITING PRIMARY SHIFT SCHEDULE, AVAILABLE FOR 3000/4000 PRODUCT FAMILIES ONLY		

Prepared for:
 Sheldon Seward
 TEREX UTILITIES BB
 500 OAKWOOD RD
 WATERTOWN, SD 57201
 Phone: 605-882-5515

Prepared by:
 Zachary Burt
 FOUR STAR FREIGHTLINER OF
 MONTGOMERY
 3140 HAYNEVILLE ROAD
 MONTGOMERY, AL 36108
 Phone: 334-263-1085

Data Code	Description	Weight Front	Weight Rear
84F-018	S7 ECONOMY LIMITING SECONDARY SHIFT SCHEDULE, AVAILABLE FOR 3000/4000 PRODUCT FAMILIES ONLY		
84G-018	2600 RPM PRIMARY MODE SHIFT SPEED		
84H-016	2400 RPM SECONDARY MODE SHIFT SPEED		
84J-000	ENGINE BRAKE RANGE PRESELECT RECOMMENDED BY DTNA AND ALLISON, THIS DEFINED BY ENGINE AND VOCATIONAL USAGE		
84K-000	ENGINE BRAKE RANGE ALTERNATE PRESELECT RECOMMENDED BY DTNA AND ALLISON, THIS DEFINED BY ENGINE AND VOCATIONAL USAGE		
84N-200	FUEL SENSE 2.0 DISABLED - PERFORMANCE - TABLE BASED		
84U-000	DRIVER SWITCH INPUT - DEFAULT - NO SWITCHES		
353-023	VEHICLE INTERFACE WIRING CONNECTOR WITHOUT BLUNT CUTS, AT END OF FRAME		
34C-001	ELECTRONIC TRANSMISSION CUSTOMER ACCESS CONNECTOR FIREWALL MOUNTED		
362-823	CUSTOMER INSTALLED CHELSEA 280 SERIES PTO		
363-001	PTO MOUNTING, LH SIDE OF MAIN TRANSMISSION ALLISON		
341-018	MAGNETIC PLUGS, ENGINE DRAIN, TRANSMISSION DRAIN, AXLE(S) FILL AND DRAIN		
345-003	PUSH BUTTON ELECTRONIC SHIFT CONTROL, DASH MOUNTED		
97G-004	TRANSMISSION PROGNOSTICS - ENABLED 2013		
370-015	WATER TO OIL TRANSMISSION COOLER, IN RADIATOR END TANK		
346-013	TRANSMISSION OIL CHECK AND FILL WITH CROSSOVER TO CLEAR LH PTO AND DIRECT MOUNT PUMP		
35T-001	SYNTHETIC TRANSMISSION FLUID (TES-295 COMPLIANT)		

Front Axle and Equipment

400-1A7	DETROIT DA-F-13.3-3 13,300# FF1 71.5 KPI/3.74 DROP SINGLE FRONT AXLE
402-049	MERITOR 16.5X5 Q+ CAST SPIDER CAM FRONT BRAKES, DOUBLE ANCHOR, FABRICATED SHOES
403-002	NON-ASBESTOS FRONT BRAKE LINING

Prepared for:
 Sheldon Seward
 TEREX UTILITIES BB
 500 OAKWOOD RD
 WATERTOWN, SD 57201
 Phone: 605-882-5515

Prepared by:
 Zachary Burt
 FOUR STAR FREIGHTLINER OF
 MONTGOMERY
 3140 HAYNEVILLE ROAD
 MONTGOMERY, AL 36108
 Phone: 334-263-1085

Data Code	Description	Weight Front	Weight Rear
419-001	CAST IRON OUTBOARD FRONT BRAKE DRUMS		
409-006	FRONT OIL SEALS		
408-001	VENTED FRONT HUB CAPS WITH WINDOW, CENTER AND SIDE PLUGS - OIL		
416-022	STANDARD SPINDLE NUTS FOR ALL AXLES		
405-002	MERITOR AUTOMATIC FRONT SLACK ADJUSTERS		
536-050	TRW THP-60 POWER STEERING		
539-003	POWER STEERING PUMP		
534-015	2 QUART SEE THROUGH POWER STEERING RESERVOIR		
40T-001	MINERAL SAE 80/90 FRONT AXLE LUBE		
Front Suspension			
620-1D8	13,300# TAPERLEAF FRONT SUSPENSION	75	
619-005	MAINTENANCE FREE RUBBER BUSHINGS - FRONT SUSPENSION		
* 62H-012	FRONT SUSPENSION WITH LEFT HAND AND RIGHT HAND OFFSET SHACKLE BRACKETS		
410-001	FRONT SHOCK ABSORBERS		
Rear Axle and Equipment			
420-1N0	MS-21-14X 21,000# R-SERIES SINGLE REAR AXLE		10
421-557	5.57 REAR AXLE RATIO		
424-001	IRON REAR AXLE CARRIER WITH STANDARD AXLE HOUSING		
386-073	MXL 17T MERITOR EXTENDED LUBE MAIN DRIVELINE WITH HALF ROUND YOKES		
452-001	DRIVER CONTROLLED TRACTION DIFFERENTIAL - SINGLE REAR AXLE		20
878-018	(1) DRIVER CONTROLLED DIFFERENTIAL LOCK REAR VALVE FOR SINGLE DRIVE AXLE		
87B-004	BLINKING LAMP WITH EACH MODE SWITCH, DIFFERENTIAL UNLOCK WITH IGNITION OFF, ACTIVE <5 MPH		
423-020	MERITOR 16.5X7 Q+ CAST SPIDER CAM REAR BRAKES, DOUBLE ANCHOR, FABRICATED SHOES		
433-002	NON-ASBESTOS REAR BRAKE LINING		
434-012	BRAKE CAMS AND CHAMBERS ON REAR SIDE OF DRIVE AXLE(S)		
451-023	CONMET CAST IRON REAR BRAKE DRUMS		
440-006	REAR OIL SEALS		

Prepared for:
 Sheldon Seward
 TEREX UTILITIES BB
 500 OAKWOOD RD
 WATERTOWN, SD 57201
 Phone: 605-882-5515

Prepared by:
 Zachary Burt
 FOUR STAR FREIGHTLINER OF
 MONTGOMERY
 3140 HAYNEVILLE ROAD
 MONTGOMERY, AL 36108
 Phone: 334-263-1085

Data Code	Description	Weight Front	Weight Rear
426-100	WABCO TRISTOP D LONGSTROKE 1-DRIVE AXLE SPRING PARKING CHAMBERS		
428-002	MERITOR AUTOMATIC REAR SLACK ADJUSTERS		
41T-002	CURRENT AVAILABLE SYNTHETIC 75W-90 REAR AXLE LUBE		
Rear Suspension			
622-1MJ	23,000# 52 INCH VARIABLE RATE MULTI-LEAF SPRING REAR SUSPENSION WITH LEAF SPRING HELPER		110
621-001	SPRING SUSPENSION - NO AXLE SPACERS		
431-001	STANDARD AXLE SEATS IN AXLE CLAMP GROUP		
Brake System			
018-002	AIR BRAKE PACKAGE		
490-100	WABCO 4S/4M ABS		
871-001	REINFORCED NYLON, FABRIC BRAID AND WIRE BRAID CHASSIS AIR LINES		
904-001	FIBER BRAID PARKING BRAKE HOSE		
412-001	STANDARD BRAKE SYSTEM VALVES		
46D-002	STANDARD AIR SYSTEM PRESSURE PROTECTION SYSTEM		
413-002	STD U.S. FRONT BRAKE VALVE		
432-003	RELAY VALVE WITH 5-8 PSI CRACK PRESSURE, NO REAR PROPORTIONING VALVE		
480-088	WABCO SYSTEM SAVER HP WITH INTEGRAL AIR GOVERNOR AND HEATER		
479-012	AIR DRYER MOUNTED UNDER HOOD		
460-001	STEEL AIR BRAKE RESERVOIRS		
607-001	CLEAR FRAME RAILS FROM BACK OF CAB TO FRONT REAR SUSPENSION BRACKET, BOTH RAILS OUTBOARD		
477-004	PULL CABLES ON ALL AIR RESERVOIR(S)		
Trailer Connections			
* 914-035	AIR CONNECTIONS FOR EOF ONLY TIED TO 2ND TO LAST XMBR WITH 72" ADDITIONAL HOSE		
296-027	PRIMARY CONNECTOR/RECEPTACLE WIRED FOR COMBINATION STOP/TURN, CENTER PIN POWERED THROUGH IGNITION WITH STOP SIGNAL PREWIRE PACKAGE		

Prepared for:
 Sheldon Seward
 TEREX UTILITIES BB
 500 OAKWOOD RD
 WATERTOWN, SD 57201
 Phone: 605-882-5515

Prepared by:
 Zachary Burt
 FOUR STAR FREIGHTLINER OF
 MONTGOMERY
 3140 HAYNEVILLE ROAD
 MONTGOMERY, AL 36108
 Phone: 334-263-1085

Data Code	Description	Weight Front	Weight Rear
297-001	SAE J560 7-WAY PRIMARY TRAILER CABLE RECEPTACLE MOUNTED END OF FRAME		
335-004	UPGRADED CHASSIS MULTIPLEXING UNIT		
32A-002	UPGRADED BULKHEAD MULTIPLEXING UNIT		
Wheelbase & Frame			
545-480	4800MM (189 INCH) WHEELBASE		
546-102	7/16X3-9/16X11-1/8 INCH STEEL FRAME (11.11MMX282.6MM/0.437X11.13 INCH) 120KSI	160	280
552-063	2550MM (100 INCH) REAR FRAME OVERHANG		
55W-009	FRAME OVERHANG RANGE: 91 INCH TO 100 INCH	-50	210
AC8-99D	CALC'D BACK OF CAB TO REAR SUSP C/L (CA) : 123.43 in		
AE8-99D	CALCULATED EFFECTIVE BACK OF CAB TO REAR SUSPENSION C/L (CA) : 120.43 in		
AE4-99D	CALC'D FRAME LENGTH - OVERALL : 318.77 in		
FSS-0LH	CALCULATED FRAME SPACE LH SIDE : 87.87 in		
FSS-0RH	CALCULATED FRAME SPACE RH SIDE : 70.93 in		
553-001	SQUARE END OF FRAME		
550-001	FRONT CLOSING CROSSMEMBER		
559-001	STANDARD WEIGHT ENGINE CROSSMEMBER		
561-001	STANDARD CROSSMEMBER BACK OF TRANSMISSION		
562-001	STANDARD MIDSHIP #1 CROSSMEMBER(S)		
572-001	STANDARD REARMOST CROSSMEMBER		
565-001	STANDARD SUSPENSION CROSSMEMBER		
Chassis Equipment			
556-1AP	THREE-PIECE 14 INCH PAINTED STEEL BUMPER WITH COLLAPSIBLE ENDS	30	
558-001	FRONT TOW HOOKS - FRAME MOUNTED	15	
574-001	BUMPER MOUNTING FOR SINGLE LICENSE PLATE		
586-024	FENDER AND FRONT OF HOOD MOUNTED FRONT MUDFLAPS		
551-007	GRADE 8 THREADED HEX HEADED FRAME FASTENERS		
605-103	D15-28195-000 CENTER PUNCH TO MARK CENTERLINE OF REAR SUSPENSION ON TOP FLANGE OF FRAME		
Fuel Tanks			

Prepared for:
 Sheldon Seward
 TEREX UTILITIES BB
 500 OAKWOOD RD
 WATERTOWN, SD 57201
 Phone: 605-882-5515

Prepared by:
 Zachary Burt
 FOUR STAR FREIGHTLINER OF
 MONTGOMERY
 3140 HAYNEVILLE ROAD
 MONTGOMERY, AL 36108
 Phone: 334-263-1085

Data Code	Description	Weight Front	Weight Rear
204-215	50 GALLON/189 LITER SHORT RECTANGULAR ALUMINUM FUEL TANK - LH	20	
218-005	RECTANGULAR FUEL TANK(S)		
215-005	PLAIN ALUMINUM/PAINTED STEEL FUEL/HYDRAULIC TANK(S) WITH PAINTED BANDS		
212-007	FUEL TANK(S) FORWARD		
664-001	PLAIN STEP FINISH		
205-001	FUEL TANK CAP(S)		
122-1J1	DETROIT FUEL/WATER SEPARATOR WITH WATER IN FUEL SENSOR, HAND PRIMER AND 12 VOLT PREHEATER"	-5	
216-020	EQUIFLO INBOARD FUEL SYSTEM		
202-016	HIGH TEMPERATURE REINFORCED NYLON FUEL LINE		
Tires			
093-1YX	CONTINENTAL HSC3 11R22.5 16 PLY RADIAL FRONT TIRES	48	
094-12P	CONTINENTAL HDR2+ 11R22.5 14 PLY RADIAL REAR TIRES		92
Hubs			
418-060	CONMET PRESET PLUS PREMIUM IRON FRONT HUBS		
450-060	CONMET PRESET PLUS PREMIUM IRON REAR HUBS		
Wheels			
502-657	ACCURIDE 51408 ACCU-LITE 22.5X8.25 10-HUB PILOT 6.16 INSET 2-HAND STEEL DISC FRONT WHEELS		
505-657	ACCURIDE 51408 ACCU-LITE 22.5X8.25 10-HUB PILOT 2-HAND STEEL DISC REAR WHEELS		
496-011	FRONT WHEEL MOUNTING NUTS		
497-011	REAR WHEEL MOUNTING NUTS		
Cab Exterior			
829-071	106 INCH BBC FLAT ROOF ALUMINUM CONVENTIONAL CAB		
650-008	AIR CAB MOUNTING		
678-998	NO GRAB HANDLES		
646-023	HOOD MOUNTED CHROMED PLASTIC GRILLE		
65X-003	CHROME HOOD MOUNTED AIR INTAKE GRILLE		
644-004	FIBERGLASS HOOD		

Prepared for:
 Sheldon Seward
 TEREX UTILITIES BB
 500 OAKWOOD RD
 WATERTOWN, SD 57201
 Phone: 605-882-5515

Prepared by:
 Zachary Burt
 FOUR STAR FREIGHTLINER OF
 MONTGOMERY
 3140 HAYNEVILLE ROAD
 MONTGOMERY, AL 36108
 Phone: 334-263-1085

Data Code	Description	Weight Front	Weight Rear
727-1AF	SINGLE 14 INCH ROUND HADLEY AIR HORN UNDER LH DECK	4	
726-001	SINGLE ELECTRIC HORN		
728-001	SINGLE HORN SHIELD		
575-001	REAR LICENSE PLATE MOUNT END OF FRAME		
312-038	INTEGRAL HEADLIGHT/MARKER ASSEMBLY WITH CHROME BEZEL		
302-001	(5) AMBER MARKER LIGHTS		
294-090	OMIT STOP/TAIL/BACKUP LIGHTS AND PROVIDE WIRING FOR COMBINED STOP/TURN LIGHTS TO FOUR FEET BEYOND END OF FRAME		-5
300-015	STANDARD FRONT TURN SIGNAL LAMPS		
744-1BH	DUAL WEST COAST MOLDED-IN COLOR MIRRORS		
797-001	DOOR MOUNTED MIRRORS		
796-001	102 INCH EQUIPMENT WIDTH		
743-1AP	LH AND RH 8 INCH MOLDED-IN COLOR CONVEX MIRRORS MOUNTED UNDER PRIMARY MIRRORS		
729-001	STANDARD SIDE/REAR REFLECTORS		
275-061	PARK BRAKE REMINDER WARNING SYSTEM		
768-043	63X14 INCH TINTED REAR WINDOW		
661-003	TINTED DOOR GLASS LH AND RH WITH TINTED NON-OPERATING WING WINDOWS		
654-027	RH AND LH ELECTRIC POWERED WINDOWS, PASSENGER SWITCHES ON DOOR(S)	4	
663-013	1-PIECE SOLAR GREEN GLASS WINDSHIELD		
659-019	2 GALLON WINDSHIELD WASHER RESERVOIR WITHOUT FLUID LEVEL INDICATOR, FRAME MOUNTED		

Cab Interior

707-1AK	OPAL GRAY VINYL INTERIOR
706-013	MOLDED PLASTIC DOOR PANEL
708-013	MOLDED PLASTIC DOOR PANEL
772-006	BLACK MATS WITH SINGLE INSULATION
785-001	DASH MOUNTED ASH TRAYS AND LIGHTER
691-008	FORWARD ROOF MOUNTED CONSOLE WITH UPPER STORAGE COMPARTMENTS WITHOUT NETTING
694-010	IN DASH STORAGE BIN
742-007	(2) CUP HOLDERS LH AND RH DASH

Prepared for:
 Sheldon Seward
 TEREX UTILITIES BB
 500 OAKWOOD RD
 WATERTOWN, SD 57201
 Phone: 605-882-5515

Prepared by:
 Zachary Burt
 FOUR STAR FREIGHTLINER OF
 MONTGOMERY
 3140 HAYNEVILLE ROAD
 MONTGOMERY, AL 36108
 Phone: 334-263-1085

Data Code	Description	Weight Front	Weight Rear
680-006	GRAY/CHARCOAL FLAT DASH		
700-002	HEATER, DEFROSTER AND AIR CONDITIONER		
701-001	STANDARD HVAC DUCTING		
703-005	MAIN HVAC CONTROLS WITH RECIRCULATION SWITCH		
170-015	STANDARD HEATER PLUMBING		
130-041	VALEO HEAVY DUTY A/C REFRIGERANT COMPRESSOR		
702-002	BINARY CONTROL, R-134A		
739-033	STANDARD INSULATION		
285-013	SOLID-STATE CIRCUIT PROTECTION AND FUSES		
280-007	12V NEGATIVE GROUND ELECTRICAL SYSTEM		
324-011	DOMED DOOR ACTIVATED LH AND RH, DUAL READING LIGHTS, FORWARD CAB ROOF		
657-001	DOOR LOCKS AND IGNITION SWITCH KEYED THE SAME		
78G-002	KEY QUANTITY OF 2		
655-005	LH AND RH ELECTRIC DOOR LOCKS		
284-023	(1) 12 VOLT POWER SUPPLY IN DASH		
756-338	BASIC ISRINGHAUSEN HIGH BACK AIR SUSPENSION DRIVERS SEAT WITH MECHANICAL LUMBAR AND INTEGRATED CUSHION EXTENSION	30	
760-235	2 MAN TOOL BOX MID BACK NON SUSPENSION PASSENGER SEAT	20	
711-004	LH AND RH INTEGRAL DOOR PANEL ARMRESTS		
758-036	VINYL WITH VINYL INSERT DRIVER SEAT		
761-036	VINYL WITH VINYL INSERT PASSENGER SEAT		
763-101	BLACK SEAT BELTS		
532-002	ADJUSTABLE TILT AND TELESCOPING STEERING COLUMN	10	
540-015	4-SPOKE 18 INCH (450MM) STEERING WHEEL		
765-002	DRIVER AND PASSENGER INTERIOR SUN VISORS		

Instruments & Controls

732-004	GRAY DRIVER INSTRUMENT PANEL		
734-004	GRAY CENTER INSTRUMENT PANEL		
870-001	BLACK GAUGE BEZELS		

Prepared for:
 Sheldon Seward
 TEREX UTILITIES BB
 500 OAKWOOD RD
 WATERTOWN, SD 57201
 Phone: 605-882-5515

Prepared by:
 Zachary Burt
 FOUR STAR FREIGHTLINER OF
 MONTGOMERY
 3140 HAYNEVILLE ROAD
 MONTGOMERY, AL 36108
 Phone: 334-263-1085

Data Code	Description	Weight Front	Weight Rear
486-006	LOW AIR PRESSURE INDICATOR LIGHT AND AUDIBLE ALARM WITH (1) ADDITIONAL PARK SWITCH FOR CUSTOMER USE		
840-002	2 INCH PRIMARY AND SECONDARY AIR PRESSURE GAUGES		
198-025	INTAKE MOUNTED AIR RESTRICTION INDICATOR WITHOUT GRADUATIONS		
149-013	ELECTRONIC CRUISE CONTROL WITH SWITCHES IN LH SWITCH PANEL		
156-007	KEY OPERATED IGNITION SWITCH AND INTEGRAL START POSITION; 4 POSITION OFF/RUN/START/ACCESSORY		
811-042	ICU3S, 132X48 DISPLAY WITH DIAGNOSTICS, 28 LED WARNING LAMPS AND DATA LINKED		
160-038	HEAVY DUTY ONBOARD DIAGNOSTICS INTERFACE CONNECTOR LOCATED BELOW LH DASH		
844-001	2 INCH ELECTRIC FUEL GAUGE		
148-003	PROGRAMMABLE RPM CONTROL - ELECTRONIC ENGINE		
856-001	ELECTRICAL ENGINE COOLANT TEMPERATURE GAUGE		
864-001	2 INCH TRANSMISSION OIL TEMPERATURE GAUGE		
830-017	ENGINE AND TRIP HOUR METERS INTEGRAL WITHIN DRIVER DISPLAY		
372-051	CUSTOMER FURNISHED AND INSTALLED PTO CONTROLS		
852-002	ELECTRIC ENGINE OIL PRESSURE GAUGE		
679-001	OVERHEAD INSTRUMENT PANEL		
746-137	AM/FM/WB WORLD TUNER RADIO WITH BLUETOOTH, USB AND AUXILIARY INPUTS, J1939	10	
747-001	DASH MOUNTED RADIO		
750-002	(2) RADIO SPEAKERS IN CAB		
753-008	AM/FM ANTENNA MOUNTED ON LH SIDE MIRROR		
810-027	ELECTRONIC MPH SPEEDOMETER WITH SECONDARY KPH SCALE, WITHOUT ODOMETER		
817-001	STANDARD VEHICLE SPEED SENSOR		
812-001	ELECTRONIC 3000 RPM TACHOMETER		
162-011	IDLE LIMITER, ELECTRONIC ENGINE		
482-001	BW TRACTOR PROTECTION VALVE		

Prepared for:
 Sheldon Seward
 TEREX UTILITIES BB
 500 OAKWOOD RD
 WATERTOWN, SD 57201
 Phone: 605-882-5515

Prepared by:
 Zachary Burt
 FOUR STAR FREIGHTLINER OF
 MONTGOMERY
 3140 HAYNEVILLE ROAD
 MONTGOMERY, AL 36108
 Phone: 334-263-1085

Data Code	Description	Weight Front	Weight Rear
883-001	TRAILER HAND CONTROL BRAKE VALVE		
836-015	DIGITAL VOLTAGE DISPLAY INTEGRAL WITH DRIVER DISPLAY		
660-008	SINGLE ELECTRIC WINDSHIELD WIPER MOTOR WITH DELAY		
304-001	MARKER LIGHT SWITCH INTEGRAL WITH HEADLIGHT SWITCH		
882-004	TWO VALVE PARKING BRAKE SYSTEM WITH WARNING INDICATOR		
299-013	SELF CANCELING TURN SIGNAL SWITCH WITH DIMMER, WASHER/WIPER AND HAZARD IN HANDLE		
298-039	INTEGRAL ELECTRONIC TURN SIGNAL FLASHER WITH HAZARD LAMPS OVERRIDING STOP LAMPS		

Design

065-000	PAINT: ONE SOLID COLOR		
---------	------------------------	--	--

Color

980-5F6	CAB COLOR A: L0006EY WHITE ELITE EY		
986-020	BLACK, HIGH SOLIDS POLYURETHANE CHASSIS PAINT		
962-972	POWDER WHITE (N0006EA) FRONT WHEELS/RIMS (PKWHT21, TKWHT21, W, TW)		
966-972	POWDER WHITE (N0006EA) REAR WHEELS/RIMS (PKWHT21, TKWHT21, W, TW)		
964-6Z7	BUMPER PAINT: FP24812 ARGENT SILVER DUPONT FLEX		
963-003	STANDARD E COAT/UNDERCOATING		

Certification / Compliance

996-001	U.S. FMVSS CERTIFICATION, EXCEPT SALES CABS AND GLIDER KITS		
---------	---	--	--

Raw Performance Data

AE8-99D	CALCULATED EFFECTIVE BACK OF CAB TO REAR SUSPENSION C/L (CA) : 120.43 in		
---------	--	--	--

Sales Programs

NO SALES PROGRAMS HAVE BEEN SELECTED

T O T A L V E H I C L E S U M M A R Y

Prepared for:
Sheldon Seward
TEREX UTILITIES BB
500 OAKWOOD RD
WATERTOWN, SD 57201
Phone: 605-882-5515

Prepared by:
Zachary Burt
FOUR STAR FREIGHTLINER OF
MONTGOMERY
3140 HAYNEVILLE ROAD
MONTGOMERY, AL 36108
Phone: 334-263-1085

Weight Summary

	Weight Front	Weight Rear	Total Weight
Factory Weight ⁺	6401 lbs	4315 lbs	10716 lbs
<hr/>			
Total Weight ⁺	6401 lbs	4315 lbs	10716 lbs

Extended Warranty

**WAG-010 TOWING: 1 YEAR/UNLIMITED MILES/KM EXTENDED TOWING
COVERAGE \$550 CAP FEX APPLIES (AT NO ADDITIONAL CHARGE)**

(+) Weights shown are estimates only.

If weight is critical, contact Customer Application Engineering.

(***) All cost increases for major components (Engines, Transmissions, Axles, Front and Rear Tires) and government mandated requirements, tariffs, and raw material surcharges will be passed through and added to factory invoices.